

# Set 1 Assessment Guide – Assistant Electrician – L3



**Sector:** Construction

**Occupation:** Construction electrical works

**Reference id:** CON/Q0602 ver. 1.0



## Table of Contents

1. Qualification structure .....	3
2. Guidance for assessors .....	5
3. Trainee guidance.....	10
4. Assessments.....	12
5. Practical/ Skill Observation Checklist.....	13
6. Tools, materials and consumable list.....	24
7. Assessment Methods/Tools.....	28
7.1 CON/N0602: Select and use hand tools, power tools, and electrical devices relevant to construction electrical works .....	28
7.2 CON/N0603: Install temporary lighting arrangement at construction sites.....	33
7.3 CON/N0604: Install LV electrical wiring at permanent structures as shown in the drawing .....	36
7.4 CON/N0605: Assemble, install and maintain temporary LV electrical panels (distribution boards) at construction site .....	39
7.5 CON/N8001: Work effectively in a team to deliver desired results at the workplace .....	43
7.6 CON/N8002: Plan and organize work to meet expected outcomes.....	46
7.7 CON/N9001: Work according to personal health, safety and environment protocol at construction site.....	48
8. Assessment summary .....	52
9. Assessment Evidence Form .....	53
10. Annexure : Assessment sheet.....	54



## 1. Qualification structure

To achieve full certification as an Assistant Electrician, trainees must complete all **seven** units, attempt and pass assessments on practical skills, viva and multiple choice synoptic test.

Sl. no	Unit No.	Title	Assessment method
001	CON/N0602	Select and use hand, power tools and electrical devices relevant to construction electrical works	Assessment of the practical skill of trainee would be based on the competency of differentiating among commonly used different electrical goods, demonstrating their use/ functions and reading of applicable electrical diagrams. Assessment of the knowledge part would be done by conducting written test, viva-voce or through observation while carrying out practical exercise.
002	CON/N0603	Install temporary lighting arrangement at construction sites	Assessment of the practical skill of trainee would be based on the competency to interpret the SLD and install temporary lighting arrangements at construction sites. Assessment of the knowledge part would be done by conducting written test, viva-voce or through observation while carrying out practical exercise.
003	CON/N0604	Install LV electrical wiring at permanent structures	Assessment of the practical skill of trainee would be based on the competency to interpret SLD and install LV electrical wiring at permanent structure. Assessment of the knowledge part would be done by conducting written test, viva-voce or through observation while carrying out practical exercise.
004	CON/N0605	Assemble, install and maintain temporary LV electrical panels (distribution boards) at construction site	Assessment of the practical skill of trainee would be based on the competency of assemble, install and maintain temporary LV electrical panels/distribution boards at construction site. Assessment of the knowledge part would be done by conducting written test, viva-voce or through observation while carrying out



			practical exercise
005	CON/N8001	Work effectively in a team to deliver desired results at the workplace	Assessment of the practical skill of trainee would be based on the competency of effective working skill and related soft skills while performing the task in a team. Assessment of the knowledge part would be done by conducting written test, viva-voce or through observation while carrying out practical exercise.
006	CON/N8002	Plan and organize work to meet expected outcomes	Assessment of the practical skill of trainee would be based on the competency of effective planning and organizing to meet expected outcomes. Assessment of the knowledge part would be done by conducting written test, viva-voce or through observation while carrying out practical exercise.
007	CON/N9001	Work according to personal health, safety and environment protocol at construction site	Assessment of the practical skill of trainee would be based on the competency of safe working practices and implementing EHS protocol. Assessment of the knowledge part would be done by conducting written test, viva-voce or through observation while carrying out practical exercise



## 2. Guidance for assessors

This qualification provides the performance criteria, skills and knowledge required to perform for the position of an Assistant Electrician at Level 3 in the Construction Sector. The role is referred to as 'Assistant Electrician'.

**Brief job description:** Assistant Electrician will be assisting level-4 electrician or superior in electrical work for the installation, repair, and maintenance of temporary LV electrical connections at the construction sites and permanent connections at residential and commercial buildings. The individual will be engaged in laying conduits for LV single phase wiring with appropriate selection and use of hand and power tools efficiently.

**Personal attributes:** The job holder is expected to be physically fit and should be able to work across various locations in withstanding extreme conditions while working at the site; well versed with tasks and functions of basic electrical work. The person must be able to work within a team, handle the various tools and materials related to electrical work safely, consciously and take responsibility for own work.

### Introduction to assessments:

The emphasis is on 'learning-by-doing' and practical demonstration of skills and knowledge based on the performance criteria. For this reason, trainees are required to complete a number of assignments to show their attainment of practical skills, viva and underpinning knowledge.

### Overview of the assessments

The weightage of skill/performance assessment is 70% and for knowledge and understanding is 30% for each NOS.

The assessment consists of two categories:

1. Performance /Skill Assessment
2. Knowledge Assessment

### Mode of Assessment

1. Demonstration/Practical for Performance /Skill Assessment
  2. Synoptic multiple choice question test.
  3. Viva
- } For Knowledge Assessment

### Grading and weightage for assessments

Trainees are graded Pass or Fail.

**The passing percentage for each QP will be 70%. To pass the Qualification Pack, every trainee should score a minimum of 70% individually in each NOS.**

Sl. no	Type of assessment	Sl. no
1.	Skill assessment by practical observation	80
2.	Knowledge assessment by synoptic MCQ test	12
3.	Knowledge assessment by viva	8



## 2.1 Performance/Skill Assessments

The performance/skill assessment will be conducted through demonstration/practical **Demonstration /Practical Assessment**

There will be **four** practical task for core NOS (i.e N0602 to 605) which the trainee must attempt and pass to demonstrate the occupational skills acquired. The practical skill for NOS – N8001, N8002 and N9001 would be judged while carrying out practical task for core NOSs. Practical assessment is externally set and externally marked.

Trainees must attempt and pass the practical test which is assessed through a practical observation checklist. Details of how to mark each task are given in the **Marking guidance** section for the practical.

The practical task is of **06 hours** duration (per trainee).The trainee has to score **343 marks** to pass the practical observation test. The grading criteria are defined below.

### Grading criteria for practical observation

NOS	Title	Performance Assessment Duration (Minutes)	Min. passing marks out of 70	Assessment Result (Total Passing Marks)
CON/N0602	Select and use hand, power tools and electrical devices relevant to construction electrical works	60	49	343≥ Pass 343< Fail
CON/N0603	Install temporary lighting arrangement at construction sites	90	49	
CON/N0604	Install LV electrical wiring at permanent structures	90	49	
CON/N0605	Assemble, install and maintain temporary LV electrical panels (distribution boards) at construction site	90	49	
CON/N8001	Work effectively in a team to deliver desired results at the workplace	*	49	
CON/N8002	Plan and organize work to meet expected outcomes	*	49	
CON/N9001	Work according to personal health, safety and environment protocol at construction site	30	49	
<b>Total</b>		6 hr	343/490	

**The assessment will be conducted in a simulated working environment. Due to this**



fact, the assessors must note that the naturally occurring evidence of competence is unavailable or infrequent. Simulation must be undertaken in a Realistic Working Environment which provides an environment that replicates the key characteristics of the workplace in which the skill to be assessed is normally employed.

This assessment guide has a section for trainees-*Section 3*. For each assessment, the marking and grading criteria are intended only for faculty and assessors.

Scheduling of the practical observations is flexible but to retain integrity of the assessment, they should be carried out as closely as possible to the written assessments.

Trainees are **not** permitted to use the observation checklist to work when completing the practical tasks but may familiarise themselves with it prior to an assessment.

### **Introducing the practical assessment to trainees**

It will be beneficial to take trainees through what is required in the practical assessments and the way in which each part will be graded. Trainees should have an opportunity to familiarise themselves with the way the tasks are graded.

Trainees may refer to their faculty for guidance on parts of the practical assignments only, though they should be aware that, especially for the practical assessments, the amount of guidance and support they are given may be reflected in the feedback and performance.

## **2.2 Knowledge Assessment**

The knowledge assessments are conducted through written test and viva.

### **1. Synoptic multiple choice question (MCQ) test**

Synoptic test is an MCQ (Multiple Choice Question) test to assess the underpinning knowledge. The synoptic MCQ tests are externally set and externally marked. This test is to be taken by the trainee after completion of all the units under controlled and invigilated conditions as closed-book test under the supervision of an assessor. Trainees can only achieve whole marks; half marks for partially answered questions are not permitted. Selection of two or more options will be marked as wrong. The answers should to be marked by pen only.

Synoptic test is of **90 minutes** duration and carries **140 marks for 7 NOS**. The test may be conducted by the assessor in the oral mode, if required, considering the lack of reading and comprehending acumen (skills) of trainees. In such cases, the assessor will mention it on top of the MCQ submitted.

### **2. Viva**

Trainees are required to take the viva test **along with** their practical observation test which is an extended part of the practical observation and assessment. Viva test is of **30 minutes** duration per learner and carry **70 Marks**. The viva assessments are externally set and externally marked. For further guidance on viva, assessors can refer to *Section 5 Viva Guidance*.

The trainee has to score **105 marks** to pass the Knowledge assessment test.



The grading criteria is as defined below

### Grading criteria for Knowledge assessment

NOS No.	Duration of Assessment (Minutes)	Knowledge Assessment		Min Passing marks	Assessment Result (Total Passing Marks)
		MCQ test	Viva		
CON/N0602	120	20	10	15	≥ 105-Pass < 105-Fail
CON/N0603		20	10	15	
CON/N0604		20	10	15	
CON/N0605		20	10	15	
CON/N8001		20	10	15	
CON/N8002		20	10	15	
CON/N9001		20	10	15	
Total	120			105/140	

### 2.2 Question papers for synoptic test

The question paper of the synoptic test is a confidential document. It will be held under the custody of Assessment body. Every assessment body should prepare the question papers and get it approved from CSDCI. The centres need to follow the indenting process to obtain the question paper to administer the test.

### 2.3 Authenticity

Centres are reminded to check for authenticity of work where trainees may be using texts and the internet to complete tasks.

### 2.4 Feedback

Assessors must provide feedback on every occasion when a skills observation takes place. A pro forma for feedback is included in this assessment guide (see *Section 4*).

### 2.5 Trainee records of coursework

Trainees should be encouraged to keep their work carefully in a portfolio or scrapbook. This may be an unfamiliar form of record keeping for some but it is a good discipline which will benefit them when they progress in their learning and training.

### 2.6 Recording sheets

The recording sheets are also provided in *Section 4 Assessments*.

### 2.7 Codes of practice

Safe working practices, health and safety and codes of practice associated with the industry must always be adhered to.

### 2.8 Health and safety

The requirement to follow safe working practices is an integral part of all assessments and it is the responsibility of centres to ensure that all relevant health and safety requirements are in place before trainees start practical assessments.

Should a trainee fail to follow health and safety practice and procedures during an assessment, the assessment must be stopped and the trainee advised of the reasons why. In case of doubts, guidance should be sought from the SSC.





## **2.9 Verification of assignments**

By using marking checklists, verifiers can check that evidence for an assignment is complete and can ensure that allocation of marks has been fair and beyond dispute.

## **2.10 Internal quality assurance**

Approved centres must have effective quality assurance systems to ensure optimum delivery and assessment of qualifications.

Quality assurance includes initial centre approval, qualification approval and the centre's own internal procedures for monitoring quality. Centres are responsible for internal quality assurance and CSDCI and Assessment body are jointly responsible for external quality assurance.

Full details and guidance on the internal and external quality assurance requirements and procedures, are provided by CSDCI from time to time.

The Assessment bodies are required to retain copies of trainees' assessment records and photographic evidence (in presence of trainee performing task) for three years after assessment.

## **2.11 Evidence Collection by the Assessor**

1. The assessor needs to collect a copy of the attendance for the training done. The attendance sheet needs to be signed by the Training Centre Head.
2. The centre head also needs to declare that all the students appearing in the assessments have a minimum attendance of 80% for the training.
3. The assessor needs to verify the authenticity of the candidate by checking the photo ID card issued by the institute as well as any one Photo ID card issued by the Central/ State Government. The same needs to be mentioned in the attendance sheet. Where ever required, the assessor can authenticate and cross verify trainee's credentials in the enrolment form.
4. The assessor needs to punch the trainee's roll number on all the final job pieces of learners. Different sections can have alpha numbering such as if a student's roll number is 123 then the three pieces submitted by that student can be numbered as 123a, 123b and 123c.
5. The assessor needs to take a group photograph of all the students along with the assessor standing in the middle and with the centre name/banner at the back, as evidence.
6. The assessor needs to carry a camera to click photographs of the trainees working on the job and giving theory exam as evidence.
7. The assessor also needs to carry a photo ID card.
8. Assessment Evidence Form (provided after the practical marks sheet), the assessor should place the final photographic evidence in the space provided as evidence, from appropriate angles/sides of the final job piece submitted.



### 3. Trainee guidance

#### 3.1 Information for trainees

The assessment requires a trainee to perform a combination of tasks as given below:

The trainee will be required to:

- Demonstrate the occupational skills and competencies as mentioned in the Qualification Pack.
- Demonstrate knowledge, understanding and skills as mentioned in the Occupational Packs.

#### Before the final assessments

The training partner (TP) will intimate that the trainees are ready for the assessment. The date and time of assessment would be intimated by the CSDCI.

The trainee is required to reach the assessment venue at the scheduled date and time. TP is required to circulate/download the information regarding the assessment to the trainee. Failure to reach the assessment venue for the theory or the practical test as per the schedule would be considered absent. In exceptional cases, an assessor can give a maximum of half hour concession time for late coming.

The trainee is required to carry their Institutes photo ID card as well as a government issued photo ID card for verification on all days of assessments.

Any misbehaviour/unethical practice by a trainee would lead to disqualification of the trainee.

The assessment comprises of three categories.

1. Theory (Synoptic multiple choice question test)
2. Practical (Job piece)
3. Viva

The first day of assessment will have the theory test followed by practical and viva in smaller batches (20-30 trainee).

#### Assessment Brief

Details of the three categories of assessments are mentioned below.

#### 1. Theory (Synoptic multiple choice question)

Synoptic test is a Multiple Choice Question (MCQ) test to assess the underpinning knowledge and skills and is to be taken by the trainee at the start of the assessment under controlled and invigilated conditions as a closed-book test.

The synoptic test comprises of 50 questions and of 90 minutes duration.

#### 2. Viva

Trainees are required to take the viva test along with their practical observation test which is an extended part of the practical observation and assessment. Viva test is of **30 minutes** duration per learner and carry 70 Marks.

A trainee has to score at least **105 marks** to pass the knowledge assessment.

#### Grading criteria for Knowledge assessment

NOS No.	Duration of Assessment (Minutes)	Knowledge Assessment		Min Passing marks	Assessment Result (Total Passing Marks)
		MCQ test	Viva		



CON/N0602	120	20	10	15	≥ 105-Pass < 105-Fail
CON/N0603		20	10	15	
CON/N0604		20	10	15	
CON/N0605		20	10	15	
CON/N8001		20	10	15	
CON/N8002		20	10	15	
CON/N9001		20	10	15	
<b>Total</b>	<b>120</b>			<b>105/140</b>	

### 3. Performance/skill assessments

Trainees will be briefed on the practical observation and checklist to familiarise them on observation methodology. The trainees would be assessed on their working as well as their final product. Trainees are suggested to read the Qualification Pack to familiarise on Performance Criteria, Knowledge, Understanding and Skills.

The practical task is for **6 hours per trainee**. A trainee has to score at least **343 marks** to pass the practical observation test.

#### Grading criteria for Performance/Skill Assessments

NOS	Title	Performance Assessment Duration (Minutes)	Min. passing marks out of 70	Assessment Result (Total Passing Marks)
CON/N0602	Select and use hand, power tools and electrical devices relevant to construction electrical works	60	49	343≥ Pass 343< Fail
CON/N0603	Install temporary lighting arrangement at construction sites	90	49	
CON/N0604	Install LV electrical wiring at permanent structures	90	49	
CON/N0605	Assemble, install and maintain temporary LV electrical panels (distribution boards) at construction site	90	49	
CON/N8001	Work effectively in a team to deliver desired results at the workplace	*	49	
CON/N8002	Plan and organize work to meet expected outcomes	*	49	
CON/N9001	Work according to personal health, safety and environment protocol at construction site	30	49	
<b>Total</b>		<b>6 hr</b>	<b>343/490</b>	



## 4. Assessments

Assessments for the job role of Assistant Electrician are conducted to gauge and assess the trainees' competencies and professional expertise as well as their skill and knowledge in the specified area (construction electrical works).

During the practical task, trainees will be assessed on their attention to detail, workmanship, quality of finished product, time management, etc., based on the performance criteria (PC), knowledge and understanding and their professional and soft skills as specified in the qualification pack. They will be graded for all their assessments based on the approved assessment strategy which is signed off by CSDCI.

The performance criteria checklist as a guide for all qualifications are given in section 5.0. Assessment tools in the form of a sample set of practical, theory and viva questions for each NOS is given as a guide in section 6 to 7. The assessment evidence, overall summary and NOS wise summary is given in section 8 to 10..



## 5. Practical/ Skill Observation Checklist

Assistant Electrician		
1. Learner Name: _____		
2. Enrolment No: _____		3. Centre: _____
<p><b>Guidance to assessors:</b></p> <p>1. Assessor must exhibit the performance criteria checklist to the learners before the commencement of the practical and explain them how the learners will be observed and graded during the practical assessment. However, the learners are not allowed to use this checklist during the course of the assessment or task.</p> <p>2. Assessor must ensure that all the tools listed in the "List of tools" are made available by the centre to every learner being assessed.</p>		
Practical	Details	Marks
<b>CON/N0602: Select and use hand, power tools and electrical devices relevant to construction electrical works</b>		
1	PC1. select and handle appropriate hand and power tools for establishing/ terminating electrical connections as per requirement: <ul style="list-style-type: none"> <li>Select and demonstrate hand and power tools like splicer, screw driver, hacksaw blade, cutting pliers, drilling machine, chasing machines etc.</li> <li>Demonstrate handling procedure of power tools (packing/ shifting) from one place to another</li> </ul>	
	PC2. Select appropriate electrical measuring devices to examine electrical units for power interruptions/ continuity: <ul style="list-style-type: none"> <li>Select electrical measuring devices like tester, multi meter, ammeter, megger etc.</li> <li>Demonstrate use of above mentioned measuring devices</li> </ul>	
	PC3. select appropriate tools and measuring devices to trace out short circuits/ faults and leakages in electrical wiring: <ul style="list-style-type: none"> <li>Describe what is short circuit and how does it occur.</li> <li>Describe how to prevent leakages from electrical circuits</li> <li>Select and demonstrate electrical short circuits/ faults and leakages tracing devices like tester, multi meter, ammeter etc.</li> </ul>	
	PC4. select electrical devices such as starters, circuit breakers, relays as per equipment/ wiring installation rating, current rating: <ul style="list-style-type: none"> <li>Describe use of mentioned devices briefly</li> <li>Describe power rating provided in the labels of electrical devices</li> <li>Select appropriate rated starters, circuit breakers and other components to install the distribution board as mentioned in the drawing.</li> </ul>	
	PC5. follow operating procedure and standards set by manufacturer while handling and using power tools and measuring devices: <ul style="list-style-type: none"> <li>Describe operating procedure of power tools briefly</li> <li>Describe power rating of tools such as hand cutting machine/ hand drill machine.</li> </ul>	
	PC6. perform basic checks on power tools prior to use: <ul style="list-style-type: none"> <li>Check for proper functioning of power tool.</li> <li>Ensure that the machine has required safety guard.</li> <li>Ensure that the cable, plug and other components used are standard and not damaged.</li> <li>Ensure that the blade or bit which is used is in good condition.</li> </ul>	



	<p>PC7. use measuring instruments to measure size and dimension of wires, conduits as per electrical installation or maintenance work requirement:</p> <ul style="list-style-type: none"> <li>• Check the size of conduits, cables, boxes with the help of Vernier calliper and measuring tape.</li> </ul>	
	<p>PC8. use hand and power tools to cut, and bend wire and conduit as per electrical installation or maintenance work requirement:</p> <ul style="list-style-type: none"> <li>• Use cutting plier, hacksaw blade to cut and bend wire, conduits.</li> </ul>	
	<p>PC9. use right tools to splice wires by stripping insulation from terminal leads and twisting wires together:</p> <ul style="list-style-type: none"> <li>• Describe standard method of wire splicing</li> <li>• Use splicer to splice the wire properly.</li> </ul>	
	<p>PC10. use appropriate hand and power tools to thread conduit ends, connect couplings, and fabricate and secure conduit support brackets:</p> <ul style="list-style-type: none"> <li>• Select and use appropriate tool to perform the task.</li> </ul>	
	<p>PC11. use appropriate hand, power tools and diagnostic devices like digital ammeter, multi meter, tong tester, earth tester or similar devices to install, repair power connections:</p> <ul style="list-style-type: none"> <li>• Describe use of mentioned devices and their working principles briefly</li> <li>• Calculate the voltage and current in the circuit after connecting a simple load by using multi meter.</li> </ul>	
	<p>PC12. maintain and upkeep of relevant tools and devices after use:</p> <ul style="list-style-type: none"> <li>• Clean and store all the tools, equipment in a proper and safe place after completion of work.</li> </ul>	
	<p>PC13. work safely as per standard practices, manufacturer's specifications and guidelines, electrical / organization safety norms while carrying out any electrical work:</p> <ul style="list-style-type: none"> <li>• Follow safe working practices as applicable and advised in the manufacturer's specifications/ guidelines.</li> </ul>	
	<b>Total</b>	<b>70</b>
<b>CON/N0603: Install temporary lighting arrangement at construction sites</b>		
<b>2</b>	<p>PC1. check and select cable, conduits, lights, sockets, temporary power distribution panels at power source and other required fixtures and accessories as per manufacturer's guidelines and specifications:</p> <ul style="list-style-type: none"> <li>• Select the cable/wire for wiring</li> <li>• Select the switches/sockets, MCB as required.</li> <li>• Select the nearest routing to establish connection</li> </ul>	
	<p>PC2. assist in /carry out laying of cables through ducts or conduits, underground or through poles (overhead) as per plans and instructions</p> <ul style="list-style-type: none"> <li>• Check excavated trench for desired excavation such as depth, width and underground service lines</li> <li>• Lay the cables by using correct method through appropriate trenches.</li> </ul>	
	<p>PC3. select the type and wattage of lights considering illumination requirement at worksite and install them at secured positions</p> <ul style="list-style-type: none"> <li>• Select the type of light as mentioned in the drawing.</li> </ul>	
	<p>PC4. fix lights and its accessories, brackets, bulkheads with screws and bolts or by other standard means, pull wires through conduit leading to connection boxes, temporary panels/ distribution boards or other temporary electrical terminals:</p> <ul style="list-style-type: none"> <li>• Select and fix light using appropriate accessories.</li> <li>• Route and connect the cable to the distribution board.</li> </ul>	



	<p>PC5. extend/ join LV electrical cable using straight through joints, splicing them together and secure joints by applying PVC insulation tapes, caps or by other safe method as and when necessary:</p> <ul style="list-style-type: none"> <li>• Extend and join the cable using proper method.</li> <li>• Remove the skin using required tool.</li> <li>• Splice the cable</li> <li>• Secure the joints using insulation tape.</li> </ul>	
	<p>PC6. carry out termination of LV cables selecting the right method as per standard practice</p> <ul style="list-style-type: none"> <li>• Follow proper sequence to carry out termination.</li> </ul>	
	<p>PC7. work safely as per electrical safety guidelines provided by manufacturer, standard safety practice or organizational safety norms while establishing or disconnecting live electrical connections: Assessor to assess this performance criteria while performing the task</p>	
	<p>PC8. upkeep of all relevant key electrical tools and fixtures:</p> <ul style="list-style-type: none"> <li>• Clean and store all the tools, equipment in a proper and safe place after completion of works</li> </ul>	
	<p>PC9. tag embedded, exposed electrical lines and other key equipment appropriately:</p> <ul style="list-style-type: none"> <li>• Tag electrical lines using required materials.</li> <li>• Display caution board near the distribution board.</li> </ul>	
	<p>PC10. repair and replace light arrangements as per instruction or requirement:</p> <ul style="list-style-type: none"> <li>• Switch off and disconnect cable.</li> <li>• Remove the screws and open the light case.</li> <li>• Replace the damaged bulb.</li> <li>• Reassemble the light case.</li> </ul>	
	<p>PC11. replace burned out bulbs, light units and ballast in light fixtures as needed:</p> <ul style="list-style-type: none"> <li>• Switch off and disconnect cable.</li> <li>• Remove the screw and open the light case.</li> <li>• Replace the damaged bulb with same configuration.</li> <li>• Reassemble the light case.</li> </ul>	
	<p>PC12. carry out relevant tests to trace out power interruptions/ continuity at lighting arrangements:</p> <ul style="list-style-type: none"> <li>• Use test bulb method to check the continuity of an existing circuit</li> <li>• Use Multi meter to check the voltage</li> <li>• Use Multi meter to check the current levels</li> <li>• Ensure Multi meter knob is selected correctly</li> </ul>	
	<p>PC13. replace damaged cable, other relevant parts as and when necessary:</p> <ul style="list-style-type: none"> <li>• Use proper method to replace damaged cable.</li> <li>• Identify and cut damaged portion of cable using required tools.</li> <li>• Follow proper method to splice the cable.</li> <li>• Protect the joint using PVC insulation tape.</li> <li>• Tag the joint for easy identification.</li> </ul>	
	<p>PC14. shift light at various locations during construction activity as per requirement:</p> <ul style="list-style-type: none"> <li>• Select short and safe route.</li> <li>• Route the cable using required supports.</li> <li>• Tie the cable in every vertical support.</li> <li>• Ensure that the cable is routed at a safer height, not less than 2</li> </ul>	



	<p>meter from ground level.</p> <ul style="list-style-type: none"> <li>• Ensure cable should not be over sagged.</li> <li>• Tie the light fixture in a safe and appropriate place.</li> <li>• Connect the supply and check for proper functioning.</li> </ul>	
	<p>PC15. replace faulty circuit breakers, fuses, switches, electrical and electronic components and wire as per requirement:</p> <ul style="list-style-type: none"> <li>• Disconnect the power supply and cable connection from Mains</li> <li>• Disconnect the load from the faulty circuit breaker</li> <li>• Dismount the faulty circuit breaker</li> <li>• Place new circuit breaker of same rating</li> <li>• Connect the load and supply terminals</li> <li>• Turn on the mains supply check for proper operation</li> </ul>	
	<p>PC16. perform preventive maintenance on diesel generators at site provided for temporary lighting (if any) at scheduled intervals as per direction of concerned authority: <u>Assessor to ask viva question</u></p>	
	<b>Total</b>	<b>70</b>
<b>CON/N0604: Install LV electrical wiring at permanent structures</b>		
<b>3</b>	<p>PC1. identify and select house wiring components (such as wires, flexible and rigid conduits, PVC raceways, wooden battens, clamps etc.) according to their specification / size:</p> <ul style="list-style-type: none"> <li>• Select the wire, conduits, as per the drawing given.</li> </ul>	
	<p>PC2. read and interpret single phase LV wiring diagram:</p> <ul style="list-style-type: none"> <li>• Read and understand the electrical drawing with respect to sequence of routing, conduit size, wire, socket, fixtures etc.</li> </ul>	
	<p>PC3. carry out necessary linear measurement to cut, bend, join conduits and cables and use them as per requirement or instruction:</p> <ul style="list-style-type: none"> <li>• Mark the location of fixtures, cable routing as per the drawing.</li> <li>• Cut the conduits and wires to require size using correct tools.</li> </ul>	
	<p>PC4. lay conduit through RCC structures (slabs, beams, walls) or through chased wall (brick wall) surface as per instruction:</p> <ul style="list-style-type: none"> <li>• Place and fix the conduits as per the drawing.</li> </ul>	
	<p>PC5. lock conduit pipe in its location by means of clamp or other standard means as per instruction:</p> <ul style="list-style-type: none"> <li>• Provide support by fixing the saddles at 500 mm spacing.</li> </ul>	
	<p>PC6. pull, push wires through conduits in order to expose them at desired locations as per requirement:</p> <ul style="list-style-type: none"> <li>• Pull the wires in an installed conduit with the help of GI wire and spring.</li> </ul>	
	<p>PC7. perform drilling, cutting work as and when necessary using appropriate hand and power tools:</p> <ul style="list-style-type: none"> <li>• Cut groove in masonry wall using chasing machine.</li> </ul>	
	<p>PC8. handle and shift electrical fixtures, fittings as per instructions within workplace:</p> <ul style="list-style-type: none"> <li>• Carry the electrical fixture by using proper method (wheel borrow) to avoid damage of fixtures.</li> </ul>	
	<p>PC9. assist in fixing of electrical fixtures and fittings as per instruction:</p> <ul style="list-style-type: none"> <li>• Fix the switch, sockets cover plate as mentioned in drawing.</li> <li>• Follow proper sequence while executing the task.</li> </ul>	
	<p>PC10. carry out termination of cables safely as per instruction:</p> <ul style="list-style-type: none"> <li>• Terminate the cable wherever required.</li> </ul>	





	<p>PC11. carry out necessary tests to electrical circuit during and post wiring activity using appropriate tools as per direction of electrician:</p> <ul style="list-style-type: none"> <li>• Check the operation of ELCB.</li> <li>• Check the operation of MCB</li> <li>• Check the continuity</li> <li>• Check the resistance by using multi meter</li> </ul>	
	<p>PC12. assist in carrying out electrical earthing work by installing earthing components as per instruction:</p> <ul style="list-style-type: none"> <li>• Connect the earthing wire to ELCB.</li> <li>• Check the continuity of earthing wire.</li> </ul>	
	<p>PC13. work safely according to manufacturer guidelines, specification, standard electrical safety practices or organizational safety and as per direction of superior authority:</p> <ul style="list-style-type: none"> <li>• Is able to follow safe working practices while performing the task.</li> </ul>	
	<b>Total</b>	<b>70</b>
<b>CON/N0605: Assemble, install and maintain temporary LV electrical panels (distribution boards) at construction site</b>		
<b>4</b>	<p>PC1. read relevant SLDs, instructions, safety guidelines, manufacturer's specifications prior to assemble temporary panel/ distribution boards:</p> <ul style="list-style-type: none"> <li>• Check the material for manufacturing date and compare it with manufacturer test certificate</li> <li>• Work as per the safety guidelines, manufacturer's specifications prior to assemble temporary panel/ distribution boards</li> </ul>	
	<p>PC2. select and install required fixtures like power sockets, switches, wires, MCBs of appropriate specification as per circuit load requirement:</p> <ul style="list-style-type: none"> <li>• Read the single line diagram</li> <li>• Select the DB of required capacity</li> <li>• Fix the MCB, ELCB, RCCB, as per the SLD</li> </ul>	
	<p>PC3. ensure tightness and safe working condition of wires, fixtures prior to connect the assembly with power source:</p> <ul style="list-style-type: none"> <li>• Check the wiring for loose connections</li> <li>• Ensure screws used are tightened properly</li> </ul>	
	<p>PC4. connect DB to main power cable and undertake standard tests to ensure its safe and desired working:</p> <ul style="list-style-type: none"> <li>• Connect the main incoming cable from metering panel to the distribution board.</li> <li>• Check the continuity of cable</li> <li>• Check the insulation of cable</li> <li>• Ensure connection is rigid and proper.</li> </ul>	
	<p>PC5. place and secure the distribution board against water, fire and other external damaging agents:</p> <ul style="list-style-type: none"> <li>• Place the DB in a firm and level surface.</li> <li>• Place the DB in secure place and barricade the area.</li> </ul>	
	<p>PC6. carry out proper termination of cables as per standard practice while connecting to the sockets of the panel:</p> <ul style="list-style-type: none"> <li>• Terminate the cable with proper method by splicing, cutting, taping, labelling.</li> </ul>	
	<p>PC7. carry out earthing of the panels as per standard procedure:</p> <ul style="list-style-type: none"> <li>• Connect the panel body to the earthing strip</li> </ul>	



	<p>PC8. work safely as per manufacturer's guidelines, specifications, standard electrical practices or organizational safety norms whichever applicable:</p> <ul style="list-style-type: none"> <li>• Is able to follow safe working practices while performing the task.</li> </ul>	
	<p>PC9. check and ensure necessary tagging, barricading near to the live/ active electrical distribution boards:</p> <ul style="list-style-type: none"> <li>• Ensure tagging and barricading the distribution board using required materials. (Tags, caution board, caution tape etc.)</li> </ul>	
	<p>PC10. carry out visual inspection of the live/ active board regularly to ensure safe working condition of all components:</p> <ul style="list-style-type: none"> <li>• Is able to carry out visual inspection of the electrical components.</li> </ul>	
	<p>PC11. ensure that the live connections get discontinued after completion of daily construction works in order to minimize energy wastage and enhance working efficiency of electrical units:</p> <ul style="list-style-type: none"> <li>• Is able to minimize energy wastage and enhance working efficiency of electrical units.</li> </ul>	
	<p>PC12. respond promptly on failure/ damage or malfunctioning of panel or any of its component:</p> <ul style="list-style-type: none"> <li>• Is able to identify the failure and prepare the action plan to rectify the same.</li> </ul>	
	<p>PC13. carry out necessary tests in order to determine root cause of failure:</p> <ul style="list-style-type: none"> <li>• Is able to conduct necessary tests in order to determine the root cause or failure.</li> </ul>	
	<p>PC14. report, notify concerned authorities prior to shut down, deactivate or repair the electrical unit:</p> <ul style="list-style-type: none"> <li>• Is able to take prior approval to shut down, deactivate and repair the electrical unit.</li> </ul>	
	<p>PC15. replace, repair faulty components as per SLD, instruction, safety guideline, manufacturer's specification:</p> <ul style="list-style-type: none"> <li>• Is able to repair and replace the faulty components followed by the sequence.</li> </ul>	
	<p>PC16. carry out necessary documentation, keep records relevant to maintenance/repairing of panels as per organizational norms:</p> <ul style="list-style-type: none"> <li>• Is able to fill the maintenance checklist.</li> </ul>	
	<p>PC17. isolate the panel safely and shift to another location as and when necessary:</p> <ul style="list-style-type: none"> <li>• Barricade the area with caution tape.</li> <li>• Ensure caution board near the distribution board.</li> </ul>	
	<b>Total</b>	<b>70</b>
<b>CON/N8001: Work effectively in a team to deliver desired results at the workplace</b>		
<b>5</b>	<p>PC1. pass on work related information/ requirement clearly to the team members:</p> <ul style="list-style-type: none"> <li>• Communicate work related information clearly to the team members while performing task. Assessor may observe this skill while following tasks are being performed by assessee</li> <li>• CON/N0603: Install temporary lighting arrangement at construction sites</li> <li>• CON/N0604: Install LV electrical wiring at permanent structures</li> </ul>	
	<p>PC2. inform co-workers and superiors about any kind of deviations from work:</p> <ul style="list-style-type: none"> <li>• Inform any kind of deviation to the senior/ instructor while performing</li> </ul>	



<p>the task. Assessor may observe this skill while following tasks are being performed by assesse</p> <ul style="list-style-type: none"> <li>• CON/N0603: Install temporary lighting arrangement at construction sites</li> <li>• CON/N0604: Install LV electrical wiring at permanent structures</li> </ul>	
<p>PC3. address the problems effectively and if required, report to immediate supervisor appropriately:</p> <ul style="list-style-type: none"> <li>• Address the problems to the assessor/ instructor (damaged cable/ electrical fixtures, damaged tools or consumables, material shortage, safety violation etc.) Assessor may observe this skill while following tasks are being performed by assesse</li> <li>• CON/N0603: Install temporary lighting arrangement at construction sites</li> <li>• CON/N0604: Install LV electrical wiring at permanent structures</li> <li>• CON/N0605: Assemble, install and maintain temporary LV electrical panels (distribution boards) at construction site</li> </ul>	
<p>PC4. receive instructions clearly from superiors and respond effectively on same:</p> <ul style="list-style-type: none"> <li>• Adhere to the instructions given by assessor/ instructor while performing the task Assessor may observe this skill while following tasks are being performed by assesse</li> <li>• CON/N0603: Install temporary lighting arrangement at construction sites</li> <li>• CON/N0604: Install LV electrical wiring at permanent structures</li> </ul>	
<p>PC5. communicate to team members/subordinates for appropriate work technique and method:</p> <ul style="list-style-type: none"> <li>• Instruct subordinate according to standard work technique/ guidelines Assessor may observe this skill while following tasks are being performed by assesse</li> <li>• CON/N0603: Install temporary lighting arrangement at construction sites</li> <li>• CON/N0604: Install LV electrical wiring at permanent structures</li> </ul>	
<p>PC6. seek clarification and advice as per requirement and applicability:</p> <ul style="list-style-type: none"> <li>• Seek permission/ suggestion prior to taking any decision if task is not familiar</li> <li>• Consult seniors during trouble shooting in electrical circuits Assessor to observe this skill while following task is being performed by assesse</li> <li>• CON/N0603: Install temporary lighting arrangement at construction sites</li> <li>• CON/N0604: Install LV electrical wiring at permanent structures CON/N0605: Assemble, install and maintain temporary LV electrical panels (distribution boards) at construction site</li> </ul>	



	<p>PC7. hand over the required material, tools, tackles, equipment and work fronts timely to interfacing teams:</p> <ul style="list-style-type: none"> <li>• Hand over the required tools/ materials to appropriate person post completion of work</li> <li>• Collect required tools/ devices from stores/ respective departments/ authority prior to start working</li> <li>• Complete tasks within provided time limit</li> <li>• Ensure material/ tools/ tackles are handed over to interfacing teams in safe condition Assessor may observe this skill while following tasks are being performed by assesse</li> <li>• CON/N0603: Install temporary lighting arrangement at construction sites</li> <li>• CON/N0604: Install LV electrical wiring at permanent structures</li> <li>• CON/N0605: Assemble, install and maintain temporary LV electrical panels (distribution boards) at construction site</li> </ul>	
	<p>PC8. work together with co-workers in a synchronized manner:</p> <ul style="list-style-type: none"> <li>• Work together with co-worker.</li> <li>• Adopt and promote safe working methods</li> <li>• Have coordination with other trade workers during working.</li> <li>• Report conflict to superior/ concerned authority</li> <li>• Notify other trade personnel/ concerned authorities as per laid down procedure Assessor may observe this skill while following tasks are being performed by assesse</li> <li>• CON/N0603: Install temporary lighting arrangement at construction sites</li> <li>• CON/N0604: Install LV electrical wiring at permanent structures</li> <li>• CON/N0605: Assemble, install and maintain temporary LV electrical panels (distribution boards) at construction site</li> </ul>	
	<b>Total</b>	<b>70</b>
<b>CON/N8002: Plan and organize work to meet expected outcomes</b>		
<b>6</b>	<p>PC1. understand clearly the targets and timelines set by superiors:</p> <ul style="list-style-type: none"> <li>• Interpret the instructions from seniors.</li> <li>• Describe duration of tasks to be performed to the assessor Assessor may observe this skill while following tasks are being performed by assesse</li> <li>• CON/N0603: Install temporary lighting arrangement at construction sites</li> <li>• CON/N0604: Install LV electrical wiring at permanent structures</li> <li>• CON/N0605: Assemble, install and maintain temporary LV electrical panels (distribution boards) at construction site</li> </ul>	
	<p>PC2. plan activities as per schedule and sequence:</p> <ul style="list-style-type: none"> <li>• Describe steps to be followed to execute assign task</li> <li>• Follow the sequence of work. Assessor may observe this skill while following tasks are being performed by assesse</li> <li>• CON/N0603: Install temporary lighting arrangement at construction sites</li> <li>• CON/N0604: Install LV electrical wiring at permanent structures</li> <li>• CON/N0605: Assemble, install and maintain temporary LV electrical panels (distribution boards) at construction site</li> </ul>	



<p>PC3. provide guidance to the subordinates to obtain desired outcome: PC8. engage allocated manpower in an appropriate manner:</p> <ul style="list-style-type: none"> <li>• Pass on work related information to subordinates</li> <li>• Describe use of tools/ devices to subordinates</li> </ul> <p>Assessor may observe this skill while task is being performed by assessee</p> <ul style="list-style-type: none"> <li>• CON/N0603: Install temporary lighting arrangement at construction sites</li> <li>• CON/N0604: Install LV electrical wiring at permanent structures</li> </ul>	
<p>PC4. plan housekeeping activities prior to and post completion of work:</p> <ul style="list-style-type: none"> <li>• Implement housekeeping norms and instructions</li> </ul> <p>Assessor may observe this skill while task is being performed by assessee</p> <ul style="list-style-type: none"> <li>• CON/N0603: Install temporary lighting arrangement at construction sites</li> </ul>	
<p>PC5. list and arrange required resources prior to commencement of work: PC6. select and employ correct tools, tackles and equipment for completion of desired work PC7. complete the work with allocated resources: Is able to utilise the resources properly.</p> <ul style="list-style-type: none"> <li>• Acquire tools/ materials from authorised place/ person.</li> <li>• Describe required tools/ materials for assigned tasks.</li> <li>• Use tools and materials to execute tasks</li> </ul> <p>Assessor may observe this skill while task is being performed by assessee</p> <ul style="list-style-type: none"> <li>• CON/N0603: Install temporary lighting arrangement at construction sites</li> <li>• CON/N0604: Install LV electrical wiring at permanent structures</li> <li>• CON/N0605: Assemble, install and maintain temporary LV electrical panels (distribution boards) at construction site</li> </ul>	
<p>PC9. use resources in an optimum manner to avoid any unnecessary wastage: PC10. employ tools, tackles and equipment with care to avoid damage to the same:</p> <ul style="list-style-type: none"> <li>• Is able to reduce material damage while performing task.</li> <li>• Is able to follow proper sequence of execution.</li> </ul> <p>Assessor may observe this skill while task is being performed by assessee</p> <ul style="list-style-type: none"> <li>• CON/N0603: Install temporary lighting arrangement at construction sites</li> <li>• CON/N0604: Install LV electrical wiring at permanent structures</li> <li>• CON/N0605: Assemble, install and maintain temporary LV electrical panels (distribution boards) at construction site</li> </ul>	



	<p>PC11. organize work output, materials used, tools and tackles deployed: PC12. processes adopted to be in line with the specified standards and instructions:</p> <ul style="list-style-type: none"> <li>• Is able to list and organise the material, tools and tackles used.</li> <li>• Is able to follow standard procedures while performing the task.</li> <li>• Is able to follow safe working practices while performing the task</li> </ul> <p>Assessor may observe this skill while task is being performed by assessee</p> <ul style="list-style-type: none"> <li>• CON/N0603: Install temporary lighting arrangement at construction sites</li> <li>• CON/N0604: Install LV electrical wiring at permanent structures</li> <li>• CON/N0605: Assemble, install and maintain temporary LV electrical panels (distribution boards) at construction site</li> </ul>	
	<b>Total</b>	
<b>CON/N9001: Work according to personal health, safety and environment protocol at construction site</b>		
<b>7</b>	<p>PC1. Identify and report any hazard, risks or breaches in site safety to the appropriate authority PC6. Use appropriate Personal Protective Equipment (PPE) as per work requirements including: Is able to identify and demonstrate the use of following PPE:</p> <ul style="list-style-type: none"> <li>• Head Protection (Helmets)</li> <li>• Ear protection.</li> <li>• Fall Protection.</li> <li>• Foot Protection.</li> <li>• Face and Eye Protection.</li> <li>• Hand and Body Protection.</li> <li>• Respiratory Protection (if required).</li> </ul> <p><b><u>*The skill is mandatory to be exhibited by assessee to pass the NOS</u></b></p> <p>Assessor may observe this skill while task is being performed by assessee</p> <ul style="list-style-type: none"> <li>• CON/N0603: Install temporary lighting arrangement at construction sites</li> <li>• CON/N0604: Install LV electrical wiring at permanent structures</li> <li>• CON/N0605: Assemble, install and maintain temporary LV electrical panels (distribution boards) at construction site</li> </ul> <p>PC2. Follow emergency and evacuation procedures in case of accidents, fires, natural calamities</p> <p>Assessor to ask viva question</p> <p>PC3. Follow recommended safe practices in handling construction materials, including chemical and hazardous material whenever applicable</p> <ul style="list-style-type: none"> <li>• Not applicable to the job role</li> </ul> <p>PC4. Participate in safety awareness programs like Tool Box Talks, safety demonstrations, mock drills, conducted at site PC5. Identify near miss, unsafe condition and unsafe act</p>	



	<p>PC10. Follow safety protocol and practices as laid down by site EHS department. PC12. Apply ergonomic principles wherever required.</p> <ul style="list-style-type: none"> <li>Describe electrical hazards</li> <li>Describe fire hazards</li> <li>Describe use of signage, posters, barricading</li> <li>Describe ergonomic principle to be adopted while working</li> </ul>	
	<p>PC7. Handle all required tools, tackles, materials &amp; equipment safely. PC8. Follow safe disposal of waste, harmful and hazardous materials as per EHS guidelines PC10. Follow safety protocol and practices as laid down by site EHS department.</p> <p>Assessor may observe this skill while task is being performed by assessee</p> <ul style="list-style-type: none"> <li>CON/N0603: Install temporary lighting arrangement at construction sites</li> <li>CON/N0604: Install LV electrical wiring at permanent structures</li> <li>CON/N0605: Assemble, install and maintain temporary LV electrical panels (distribution boards) at construction site</li> </ul>	
	<p>PC9. Install and apply properly all safety equipment as instructed</p> <ul style="list-style-type: none"> <li>Install electrical safety devices starters, MCBs etc. as necessary to the circuits</li> <li>Carry out proper termination of cables</li> <li>Carry out proper joining of the cable</li> </ul> <p>Assessor may observe this skill while task is being performed by assessee</p> <ul style="list-style-type: none"> <li>CON/N0603: Install temporary lighting arrangement at construction sites</li> <li>CON/N0604: Install LV electrical wiring at permanent structures</li> <li>CON/N0605: Assemble, install and maintain temporary LV electrical panels (distribution boards) at construction site</li> </ul>	
	<p>PC11. Collect and deposit construction waste into identified containers before disposal, separate containers that may be needed for disposal of toxic or hazardous wastes</p> <ul style="list-style-type: none"> <li>Is able to clean and clear the area.</li> <li>Is able to collect and deposit construction waste into identified containers.</li> <li>Is able to follow safe disposal of waste.</li> </ul> <p>Assessor may observe this skill while task is being performed by assessee</p> <ul style="list-style-type: none"> <li>CON/N0603: Install temporary lighting arrangement at construction sites</li> <li>CON/N0604: Install LV electrical wiring at permanent structures</li> <li>CON/N0605: Assemble, install and maintain temporary LV electrical panels (distribution boards) at construction site</li> </ul>	
	<p><b>Total</b></p>	<p><b>70</b></p>
	<p><b>Grand Total</b></p>	<p><b>490</b></p>



## 6. Tools, materials and consumable list

Below tools list is prepared based on the practical questions for the NOS CON/N0602, CON/N0603, CON/N0604 and CON/N0605.

Tools and consumables required				
Category	Sl.no.	Particulars	Specification	Quantity
Tools	1.	Combination pliers	Heavy duty	4 sets
	2.	Nose pliers	Long nose	4 sets
	3.	Round nosed pliers	Heavy duty	4 sets
	4.	Channel lock pliers	Heavy duty	4 sets
	5.	Linesman pliers	Heavy duty	4 sets
	6.	Connectors	Any reputed brand	4 sets
	7.	Screwdriver with tester	Any reputed brand	4 sets
	8.	Screw driver	Any reputed brand	4 sets
	9.	Connector screw driver	Any reputed brand	4 sets
	10.	Nut drivers	Any reputed brand	4 sets
	11.	Hacksaw frames	Any reputed brand	4 sets
	12.	Hammer	3 lb/5lb	4 sets
	13.	Spanner (Set)	Any reputed brand	4 sets
	14.	Soldering iron with flux and lead	Any reputed brand	4 sets
	15.	Crimping tool	Any reputed brand	4 sets
	16.	Razor blade knife	Any reputed brand	4 sets
	17.	Side cutter	Any reputed brand	4 sets
	18.	Snipper	Any reputed brand	4 sets
	19.	Allen key set	Any reputed brand	4 sets
	20.	Tubular spanner	Any reputed brand	4 sets
	21.	Pipe wrench/Chain wrench	Any reputed brand	4 sets
	22.	Conduit threading die set	Any reputed brand	4 sets
	23.	Aluminium ladder	Any reputed brand	4 sets
	24.	Pipe vice	Any reputed brand	4 sets
	25.	Bench vice	Any reputed brand	4 sets
	26.	Steel wire (Pull wire)	Any reputed brand	4 sets
	27.	Hillman rollers	Any reputed brand	4 sets
	28.	Pellatt trucks	Any reputed brand	4 sets
	29.	Wire strippers	Any reputed brand	4 sets
	30.	Chisel	Flat	4 sets
	31.	Knockout hole punch	Any reputed brand	4 sets
	32.	Fish tapes	Any reputed brand	4 sets
	33.	Fish poles	Any reputed brand	4 sets
	34.	Flash light/torch	Any reputed brand	4 sets
Measuring	1.	Ammeter	10 amp	4 sets





instruments	2.	Voltmeter	440 V	4 sets
	3.	Wattmeter	2KW	4 sets
	4.	Ohmmeter	1000 $\Omega$	4 sets
	5.	Multimeter	Any reputed brand	4 sets
	6.	Megger	0 to 100 G ohm	4 sets
	7.	Neon tester	Any reputed brand	4 sets
	8.	Lux meter	Any reputed brand	4 sets
	9.	Measuring tape	5 meter	4 sets
	10.	Spirit level	1 meter length	4 sets
	Power tools	1.	Drilling machine	Medium duty
2.		Labelling machines	Medium duty	4 sets
3.		Grinding machine	Medium duty	4 sets
4.		Abrasive cutter	Any reputed brand	4 sets
5.		Chasing machine	Medium duty	4 sets
Materials required for practicals	1.	Electrical distribution board	450X600 mm (wooden)	1 per learner
	2.	Electrical socket (set)	Industrial socket	1 per learner
	3.	Tungsten bulb/ CFL/FSL bulb	60W/15W	1 per learner
	4.	Halogen lamp	150W	1 per learner
	5.	wall socket	5-hole 6A 230V	1 per learner
	6.	Simple switchboard	Any reputed brand	1 per learner
	7.	Mains breaker switch	Double pole	1 per learner
	8.	Earth Leakage Circuit Breaker (ELCB)	63A 4P	1 per learner
	9.	Miniature Circuit Breaker (MCB)	40A 4P	1 per learner
	10.	Miniature Circuit Breaker (MCB)	16A	4 per learner
	11.	FRLS wire Red	4sq.mm	50 M
	12.	FRLS wire black	4sq.mm	50 M
	13.	FRLS wire green	2.5sq.mm	50 M
	14.	Power socket	16/20amp	25
	15.	Single pole switch	16/20amp	25
	16.	GI coated metal Box	3 Modular	25
	17.	Switch Plate	3 Modular	25
	18.	cover plate	3 Modular	25
	19.	PVC collars	25mm diameter	50
	20.	PVC bends	25mm diameter	50
	21.	4sq.mm lugs	Any reputed brand	50
	22.	2.5sq.mm lugs	Any reputed brand	50
	23.	MCB	16amp single pole	25



	24.	PVC insulated cable	10sq.mm		
	25.	Gang boxes	GI	As required	
	26.	Wall anchors or saddles	PVC	As required	
	27.	Insulation tape (Red, Yellow, Blue, Green, Black colour)	Any reputed brand	30 nos each	
	28.	PVC conduit pipe	2mm/HMS	60m	
	29.	Wire clips	Any reputed brand	10 packets	
	30.	Industrial Socket	5 pin	30	
	31.	Industrial Socket	3 pin	30	
	32.	Plug 3 pin	An	30	
	33.	Continuity tester	Any reputed brand	10	
	34.	Test lamp	Any reputed brand	10	
	35.	Testing probes	Any reputed brand	4 sets	
	36.	Trestle	Any reputed brand	5	
	37.	Folding trestle	Any reputed brand	5	
	38.	Hop up stool	Any reputed brand	5	
	39.	Scaffold board	Any reputed brand	5	
	40.	Hacksaw blade	Any reputed brand	20	
	Consumables	1.	Helmet	Any reputed brand	1 per learner
		2.	Face shield	Any reputed brand	1 per learner
		3.	Safety goggles	Any reputed brand	1 per learner
4.		Safety shoes	Any reputed brand	1 per learner	
5.		Safety belt	Any reputed brand	1 per learner	
6.		Insulated rubber gloves	Any reputed brand	1 per learner	
7.		Ear defenders	Any reputed brand	1 per learner	
8.		Particle masks	Any reputed brand	1 per learner	
9.		Overalls	Any reputed brand	1 per learner	
10.		Knee pad	Any reputed brand	1 per learner	
11.		Reflective jackets	Any reputed brand	1 per learner	
12.		Head torch	Any reputed brand	1 per learner	
13.		Insulated rubber mats	Any reputed brand	1 per learner	
Infrastructures	1.	Class room for theory assessment with 30 study chairs	300 sq.ft	1 per batch	
	2.	Workshop for practical assessment	900 sq.ft	1 per batch	
	3.	Masonry wall (For groove cutting and installation)	200 sq.ft	1 per batch	
	4.	Cable trench	10 meter	1 per batch	
	5.	Toilet/Urinals (Separate for gents and Ladies)	2 WC +5 urinals	1 per batch	
	6.	3 phase power supply points	Any reputed brand	As required	
	7.	Single phase power supply points	Any reputed brand	As required	



	8.	Fire extinguishers (mechanical foam, DCP, CO <sub>2</sub> and sand buckets with stand)	Any reputed brand	As required
	9.	First aid kit	Any reputed brand	As required
	10.	Tool box with lock and key	Any reputed brand	As required
	<b>Note</b> <ul style="list-style-type: none"><li>• All electrical items, used for training/assessment should be ISI marked and undergone safety checks/tests prior to use.</li><li>• Above list is for the batch size of 20 learners.</li></ul>			



## 7. Assessment Methods/Tools

### 7.1 CON/N0602: Select and use hand tools, power tools, and electrical devices relevant to construction electrical works

#### A. Practical questions

**Total Marks: 70**  
**Duration: 60 Minutes**

1. Identify and demonstrate use of hand/ measuring tools (any 5 tools): **05 marks**
  - Screwdriver
  - voltage tester
  - pliers
  - wire strippers
  - insulation tapes
  - Measuring tapes etc.
2. Identify and demonstrate use of power tools while using appropriate safety gears –
  - Hand drill machine (perform drilling of holes in wall surface/ wooden surface using 12mm drill bit) **10 marks**
  - Hand cutting machine – Cut wire, conduits, wooden planks of required size **10 marks**

(Assessor to observe this skill while performing core NOS N0605)
3. Identify and demonstrate use of common electrical measuring devices as per standard procedure of power tools (any two): **10 marks**
  - Digital Multi meter
  - Ohm Meter
  - Tong tester (Clamp-on ammeter)
  - Digital Earth Resistance Tester
  - Digital Megger
4. Describe the use of commonly used electrical fixtures, and electrical materials (any two): **05 marks**
  - Starters
  - Conductors
  - Relays
  - Circuit breakers (MCB, ELCB, RCCB)
  - Conduits (Flexible and rigid)
  - Wires and Cables
  - Electrical earthing systems and its components
5. Measure the size of given wire using a Standard Wire Gauge (SWG). **05 marks**
6. Measure the diameter using a Vernier calliper. **05 marks**
7. Measure the resistance of wires using a multi meter. **05 marks**
8. Measure and note load current in a cable by using clamp-on ammeter and pack the device post completion of the task: **15 marks**
9. **Demonstrate use of PPEs used for electrical works (any five): 05 marks**
  - Gloves used for electrical works
  - Helmet
  - Safety shoes
  - Safety harness
  - Safety goggles
  - Ear plugs
  - Different types of fire extinguisher and use

**B. Theory questions (Written)**

**Total Marks: 20**

1. Which device is used to measure current in a circuit? 2 Marks
- a. Voltmeter
  - b. Ammeter**
  - c. Tester
  - d. Megger

2. Identify the item from the image below? 2 Marks



- a. Wattmeter
- b. Digital Multi meter**
- c. Energy meter
- d. Analog multi meter

3. Which device is used to avoid overload current in a circuit? 2 Marks
- a. Residual current circuit breaker
  - b. Miniature circuit breaker**
  - c. Earth Leakage circuit breaker
  - d. Molded Case circuit breaker

4. Identify the tool from the image below? 2 Marks



- a. Channel lock plier
- b. Combination plier
- c. Nose plier
- d. Snippers**

5. Which of the following is an ideal instrument used to measure the thickness of conduit? 2 Marks

- a. Vernier Caliper**
- b. Multi meter
- c. Measuring tape
- d. Total station

6. Identify the item form the image below?

2 Marks



- a. **Semi enclosed or re-wire able fuse**
- b. Cartridge type fuse
- c. D type fuse
- d. Link type fuse

7. Which of the following tools is used to strip the insulation of cable?

2 Marks

- a. Plier
- b. Scissor
- c. **Splicer**
- d. Tester

8. Identify the type of switch form the image below?

2 Marks



- a. Key lock switch
- b. Slide switch
- c. Rotary switch
- d. **Push button switch**

9. Identify the power tool form the image below?

2 Marks



- a. Labeling machine
- b. **Drilling machine**
- c. Chasing machine
- d. Grinding machine

10. Which of the following is the right method for storing sharp tools?





2 Marks

- a. Store sharp tools along with other tools
- b. **Store sharp tools in a designated tool kit**
- c. Wrap sharp tool in paper
- d. Store sharp tools in a secret place

**C. Viva questions**

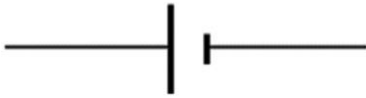
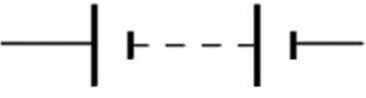
**Total Marks: 10**

1. Read and interpret Basic Electrical Symbols from given Figure (any five): 3 Marks

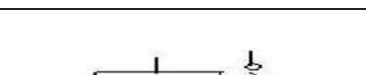
a.	
b.	
c.	
d.	
e.	
f.	
g.	

**Possible answers**

- a.Cell
- b.Battery
- c.DC supply
- d.AC supply
- e.Fuse
- f. Switch
- g.Relay

2. Read and interpret following electrical diagram:

3 Marks

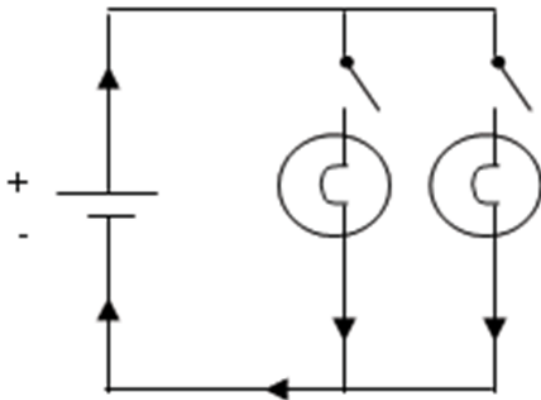

**Possible answers**

- a.Power source
- b.Switches
- c.Light bulb



3. What are the safety precautions to be taken while using power tools?

2 Marks

**Possible answers**

- a. Ensure that the operator understand the manufacturer instructions
- b. Ensure appropriate PPEs are worn
- c. Check for proper functioning
- d. Ensure that the power tool is not damaged.
- e. Ensure that the blade/bits used are in good condition.
- f. Ensure safety guard is placed and in good condition.
- g. Check for proper earthing.
- h. Ensure that the cable used are not damaged
- i. Ensure emergency equipment placed near the operation

4. State the unsafe working conditions for electrical works.

2 Marks

**Possible answers**

- a. Improper illumination
- b. Inadequate ventilation.
- c. Wet workplace and surroundings.
- d. Overcrowded and congested work places.
- e. Working in proximity of other services/electrical lines
- f. Working near flammable substances.
- g. Inappropriate use of PPEs.
- h. Inappropriately terminated/insulated cables or wires.
- i. Unguarded and faulty machineries.



## 7.2 CON/N0603: Install temporary lighting arrangement at construction sites

### A. Practical questions

Total Marks: 70

Duration: 60 Minutes

**Practical scenario:** Temporary lighting arrangement should be carried out in order to create a temporary lighting from a given electrical outlet (LV). Cable laying arrangement is to be done underground by excavating suitable trenches.

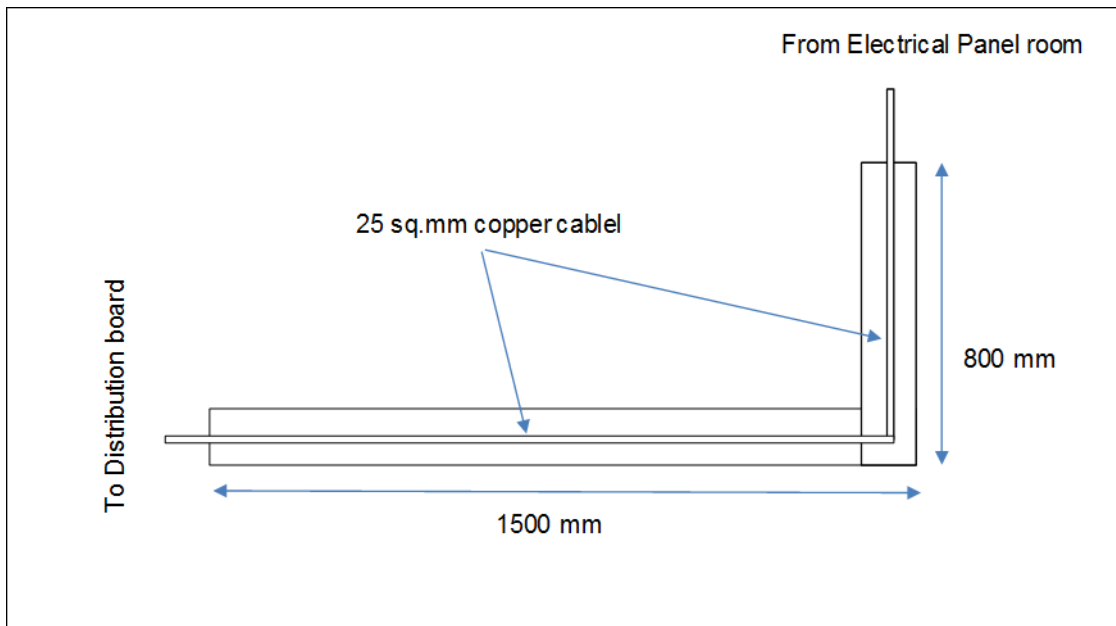

1. Check and select cable, conduits, lights, sockets and related fittings as required. **10 marks**
2. Carryout laying of cables through underground by suitable trenches. **10 marks**
3. Extend LV electrical cable using proper joints. **10 marks**
4. Terminate LV cables using right method. **10 marks**
5. Carryout earthing as per standard method. **10 marks**
  - Assessor to ask candidate to explain the earthing method.
6. Fix light and accessories as per the requirement and electrical safety guidelines. **10 marks**
7. Carry out relevant tests to trace out power interruptions/ continuity at lighting arrangements **10 marks**

### B. Theory questions (Written)

Total Marks: 20

1. What is the maximum number of 1sq.mm wires that can be drawn through a 25mm diameter conduit? **2 Marks**
  - a. 5
  - b. 2
  - c. 4
  - d. 6
2. What are the type of sockets used to provide temporary supply at a construction site? **2 Marks**
  - a. 15 amps socket
  - b. 6 amps socket
  - c. **Industrial Socket**



- d. Normal socket
3. Which method of cable joint is used for LV cables? 2 Marks
- Hot Shrinkable
  - Cold Shrinkable**
  - Termination
  - Tapping method
4. Which of the following specific components is used while terminating wires? 2 Marks
- Glands
  - Switches
  - Lugs**
  - Circuit Breakers
5. What should be the minimum size of the wire used in power circuits? 3 Marks
- 1 sq.mm
  - 2 sq.mm
  - 2.5 sq.mm**
  - 4 sq.mm
6. Which of the following is an ideal lighting fixture used in a construction site? 4 Marks
- LED lamp
  - Halogen lamp**
  - Florescent lamp
  - Fancy lamp
7. Which of the following devices is **not** used to check the continuity of supply in a circuit? 3 Marks
- Multi meter
  - Continuity tester
  - Intensity calculator**
  - Light bulb
8. What is the correct method to be followed while shifting a temporary light to another location? 1 Mark
- Turn off the switch, disconnect the plug and change location**
  - Disconnect the plug, switch off and change location
  - Pull the plug using wire, switch off and change location
  - Change location in live connection without disconnecting plug.
9. What precaution should be taken before replacing a circuit breaker? 1 Mark
- Disconnect the load
  - Disconnect the mains**
  - Check earth leakage
  - Tap the load to another operating circuit

### C. Viva questions

**Total Marks: 10**

1. What are the information's should be marked in a length of conduit pipe? 4 Marks
- Possible answers**
- Manufacturer name or trade mark
  - Nominal size of the conduit
  - Country of manufacture
  - Classification of the conduit
  - Standard Mark (ISI).
  - Manufacturing batch code



2. State the colour codes and their meaning used in electrical wiring?

4 Marks

**Possible answers**

- a.Red – Phase conductor
- b.Blue – Phase conductor
- c.Yellow – Phase conductor
- d.Black – Neutral conductor
- e.Green – Protective conductor (Earth)

3. What are the maintenance check point of a diesel generator?

2 Marks

**Possible answers**

- a.Check fuel level
- b.Check the lubricant level
- c.Check the coolant level
- d.Check for the noise and smoke
- e.Check the readings for overload or under load
- f. Check the power factor reading.
- g.Maintain a record of regular inspection



### 7.3 CON/N0604: Install LV electrical wiring at permanent structures as shown in the drawing

#### A. Practical questions

**Total Marks: 70**

**Duration: 90 Minutes.**

Candidates should able to:

1. Read and interpret Single Line Diagrams (SLDs) for below shown diagram 7 Marks
  - Is candidate able to understand the symbols mentioned in the circuit diagram given below?
  - Is able to understand the specifications mentioned in the drawing below?
2. Check and select cable, conduits, lights, sockets and related fittings as per the drawing. 7 Marks
  - Is candidate able to select appropriate able to understand the specifications mentioned in the drawing below?
3. Measure length of conduits and cables 10 Marks
4. Tag conduits through RCC structure and wall 8 Marks
5. Lock conduit pips in its location 8 Marks
6. Push & pull wires through conduits 8 Marks
7. Perform drilling and cutting work 10 Marks
8. Extend LV electrical cable using proper joints. 6 Marks
9. Terminate LV cables using right method. 6 Marks

#### Block drawing of combined lighting and power circuits

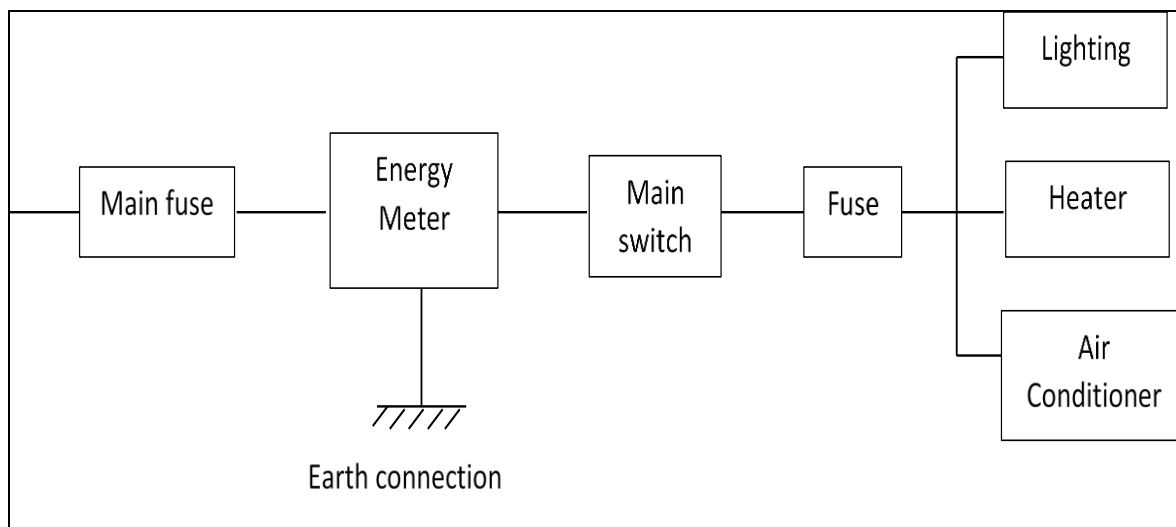

## Wiring drawing of combined lighting and power circuits

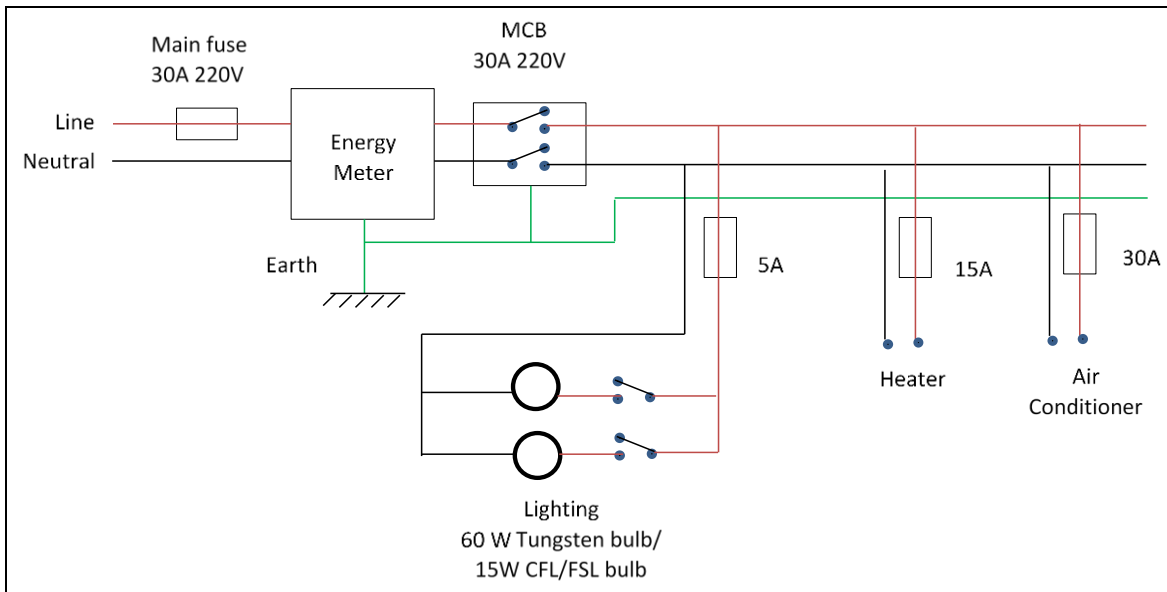

### B. Theory questions (Written)

**Total Marks: 20**

1. What should be the minimum number of wires required to install two single phase light point? 1 Mark
  - a. 3
  - b. 2
  - c. 5**
  - d. 4
  
2. Which of the following tool is used to cut a PVC conduit? 2 Marks
  - a. Plier
  - b. Splicer
  - c. Hacksaw**
  - d. Scissor
  
3. Which of the following accessories is used to hold the conduit in a grooved wall? 4 Marks
  - a. U plug**
  - b. Straight nails
  - c. Wooden wedges
  - d. Adhesive
  
4. How are electrical wires placed inside a conduit? 2 Marks
  - a. Pulled through a GI wire from one end to the other**
  - b. Pulled directly from one end to the other
  - c. Wires placed during wall conduit
  - d. Placed inside by splitting the conduit
  
5. Which of the following power tools is used to cut groove in a wall for electrical conduit? 3 Marks
  - a. Chasing machine**
  - b. Flaring machine
  - c. Bar cutting machine
  - d. Grinding machine
  
6. Why is it compulsory to fix ELCB in each distribution board? 2 Marks



- a. To provide protection from current overflow
- b. To provide protection from voltage overflow
- c. To provide protection against earth leakage**
- d. To provide lightening protection

7. Which type of test is used to check the insulation of a cable? 3 Marks
- a. Continuity
  - b. Earth leakage
  - c. Megger**
  - d. Polarity

8. Which statement is correct regarding earth resistance? 3 Marks
- a. Earth resistance should be very high
  - b. Earth resistance should be low**
  - c. Earth resistance should be equal to load connected
  - d. Earth resistance should be greater than load connected

### **C. Viva questions**

**Total Marks: 10**

1. What are the information's that can be found in a wiring diagram? 4 Marks
- Possible answers**
- a. Electrical wiring routing
  - b. System circuits
  - c. Ground point (Earth)
  - d. Power source location
  - e. Type of fixture, cable, conduit, fittings and related materials.
2. What are points to be considered while selecting a light fixture? 4 Marks
- Possible answers**
- a. Illumination requirement
  - b. Specification of the fixture
  - c. Aesthetic requirement
  - d. Type and rating of the fixture
  - e. Mounting requirement of the fixture
3. State the symbol and their meaning used in safety signage? 2 Marks
- Possible answers**
- a. Square/ rectangle – Emergency and information sign.
  - b. Circle – Mandatory or things to do.
  - c. Triangle – Warning or caution.
  - d. Circle with cross cut – prohibition or things not to do.



## 7.4 CON/N0605: Assemble, install and maintain temporary LV electrical panels (distribution boards) at construction site

### A. Practical questions

**Total Marks: 70**

**Duration: 90 Minutes.**

Candidates should be able to:

1. Check and select required materials and fittings as per the below drawing. 8 Marks
  - Candidate to select socket, MCCB, RCCB, wires as per the specifications mentioned in the below drawing.
2. Measure and mark all fittings, fixtures and components in distribution board as per the drawing. 8 Marks
  - Candidate to mark the location of fittings, fixtures in the distribution board with paint or marker.
3. Carryout required opening (Cut/hole) in distribution board using appropriate tools. 10 Marks
  - Candidate to select right tool for the right job i.e. drilling machine, drill bit, hand saw blade, wood punch etc.
4. Carryout wiring using required tools and materials as per the drawing. 15 Marks
  - Candidate to select right material with right quantity, (length of wire, number of fixtures, fittings etc.)
5. Terminate LV cables using right method. 10 Marks
  - Candidate to terminate the cable to the connecting fixtures. ( for socket, MCCB, RCCB and for out let)
6. Carryout earthing as per standard method. 8 Marks
  - Assessor to instruct candidate to explain the procedure for earthing.
7. Carry out relevant tests to trace out power interruptions/ continuity at lighting arrangements 6 Marks
  - Candidate to check the distribution board for proper functioning.
8. Place and safe guard distribution board as per the guidelines. 5 Marks
  - Candidate to safe guard the distribution board with required barricading and sign board.
  - Candidate to safe guard/cover the distribution board to avoid dust, rain water, sunlight etc.

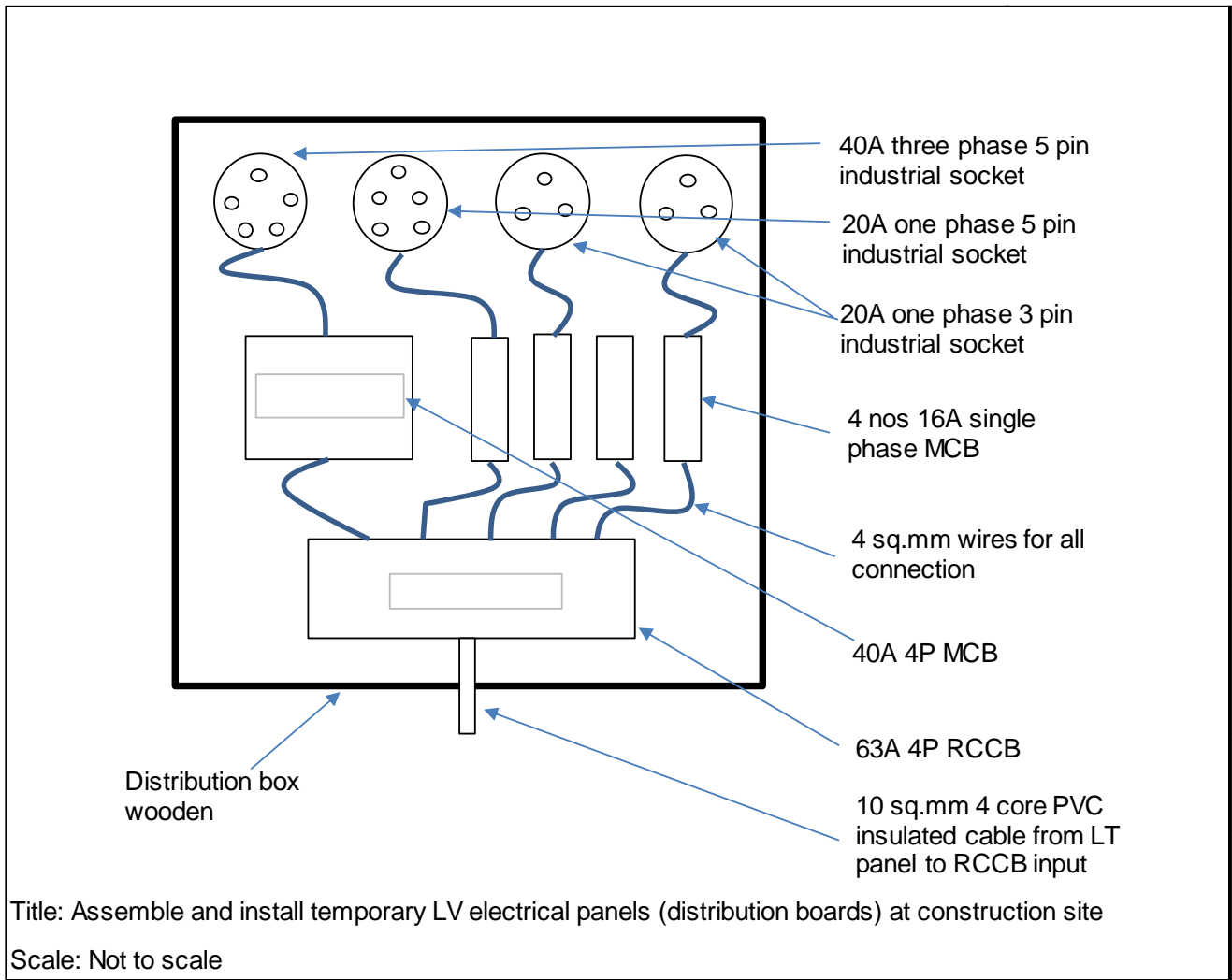

**B Theory questions (Written)**

**Total Marks: 20**

1. Which of the following is the symbol for a three phase star connection? 3 Marks
  - a. Y
  - b. I
  - c. K
  - d. N

2. What does the image below symbolize in electrical drawing? 4 Marks

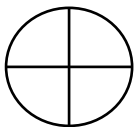

- a. **Bracket Light**
  - b. Bulkhead light
  - c. Tube light
  - d. Emergency Light
3. Where the incoming mains should be connected in a DB? 2 Marks
    - a. MCB incoming port
    - b. MCCB Incoming port
    - c. ACB incoming port
    - d. **RCCB incoming port**
  4. Which among the following is a safe place to install a distribution board? 2 Marks





- a. In a compound wall
  - b. In an area with open sky
  - c. In a wall below the roof**
  - d. In the ceiling
5. What is the purpose of using glands in wiring? 2 Marks
- a. Used to hold the cable**
  - b. Used to label the cable
  - c. Used to tag the cable
  - d. Used to strip the cable
6. What is the purpose of panel earthing? 3 Marks
- a. To provide a neutral connection
  - b. To provide phase connection
  - c. To neutralize the current
  - d. To neutralize leakage current**
7. What does the sign below indicate? 2 Marks



- a. High voltage**
  - b. Fire exit
  - c. Deep excavation
  - d. Permit required
8. How should the wire be connected in a socket? 1 Marks
- a. Connected with twisting wires
  - b. Connected with adhesive
  - c. Connected with screw**
  - d. Connected by soldering
9. When an MCB in DB should be replaced? 1 Marks
- a. If MCB is old
  - b. If MCB is not functioning properly**
  - c. When instructed by a colleague
  - d. If MCB gets heated up

### C. Viva questions

**Total Marks: 10**

1. State the standard electrical practices while installing temporary electrical panels. 6 Marks
- Possible answers**
- a. Unused openings in the panel must be closed
  - b. Conductors entering the panels must be protected from abrasion
  - c. Flexible cords and cable must be protected from damage
  - d. Panel must be provided with a cover
  - e. Metal covers must be grounded properly
  - f. Screws and nuts should be tightened properly
  - g. Each fixtures, fittings, cables should be tagged and marked for identification
2. How the electrical panels are maintained and secured? 4 Marks



**Possible answers**

- a. Check the functioning of electrical panel on daily basis
- b. Upkeep maintenance checklist
- c. Replace or repair faulty components as and when required.
- d. Keep electrical panel surrounding area clean always
- e. Barricade the area
- f. Avoid unauthorised entry
- g. Secure electrical panel from water, dust and fire



## 7.5 CON/N8001: Work effectively in a team to deliver desired results at the workplace

### A. Practical questions

70 Marks

Assessor is required to assess this NOS bases on his/her observation skill and knowledge to observe, ask questions and assess trainee while performing all core NOS's during the practical task for following points:

1. How the candidate communicates work related information to team member or to assessor. 10 Marks
  - Is the candidate able to explain the process/sequence before performing every task? (Like, installing light arrangements, preparing distribution board etc.)
  - Is the candidate able to communicate properly with other candidate while transferring level through tube level? ( while marking groove cutting layout in wall)
2. How the candidate escalated deviations to the seniors/assessor. 15 Marks
  - If the candidate found any other services (fire, plumbing, AC) line crossing the proposed electrical line.
  - If candidate changed the orientation of the wall routing due to some obstruction
3. How the candidate addresses and reports problems. 15 Marks
  - If the candidate noticed damaged tool or material (**Compulsory:** assessor to provide damaged tool or material to the candidate to assess this skill)
  - If candidate noticed shortage of materials while performing task (Assessor to provide less quantity of conduit pipes/wires to assess this skill)
  - If trainee facing problem with shortage of working space
  - If trainee found lack of illumination while performing the task.
4. How a person receive and follow the instructions given by seniors/assessor. 10 Marks
  - Is candidate able to follow class room disciplines?
  - Is candidate able to follow instructions given by assessor?
5. How a person seeks clarifications and resolves the issues raised during performing the task. 10 Marks
  - Is the candidate able to clarify if the information given for particular task is insufficient? (**Compulsory:** Assessor to provide insufficient information for a particular task to assess this skill.)
6. How a person works as a team, like, proper cooperation, timely handing over tools and materials, helping and advising team members, etc. 10 Marks
  - Is the candidate able to take support of team member (other candidate), if he needs to take tape measurements, move heavy materials etc.
  - Is the candidate able to hand over the tools timely to other candidate? (For example Tube level, hacksaw frame, groove cutting machine etc.)

### B Theory questions (Written)

Total Marks: 20

1. What is the purpose of passing work-related information to a team member? 3 Marks
  - a. **To avoid communication gap between the team members**
  - b. To fulfill requirement of the organization
  - c. To ensure the attendance of team members
  - d. To develop communication gap between the team members
2. What should be done if there is a delay in delivery of fixtures and fittings to the site? 4 Marks
  - a. Report the problem to colleagues
  - b. **Report about the delay to the senior**
  - c. Do not do anything about the problem
  - d. Carry out any other job to avoid joblessness



3. What should be done if there are different opinions found in a team while executing a task? 3 Marks
- a. **Discuss with team member and clarify the same**
  - b. Do not bother about others opinion and argue with them
  - c. Stop the work and protest with the team member
  - d. Escalate it to the management and wait for the action
4. What best can be done while working with an interfacing team? 5 Marks
- a. **Hand over the resources in time to the interfacing team**
  - b. Have unnecessary chatting with the interfacing team
  - c. Develop communication gap between the interfacing team
  - d. Develop conflict between the interfacing team
5. Which of the following is the key function of a team member? 5 Marks
- a. **Coordinating with team members**
  - b. Maintaining communication gap with team members
  - c. Always seeking help from team member
  - d. Spreading rumors within the team

### **C. Viva questions**

**Total Marks: 10**

1. What are the benefit of passing on information to colleagues? 1 Mark
- Possible answers**
- a. Ensures that information will reach every person of a team
  - b. Any deviations, or change of plan will be updated
  - c. Fulfils inline organizational requirements
  - d. No chance of misunderstanding within the team
  - e. Positive effect on progress
  - f. Clarity on work schedule and out put
  - g. Team bonding
2. What are the benefits of receiving feedback from the reporting senior? 1 Mark
- Possible answers**
- a. Know the quality of work executed.
  - b. Learn from the mistakes, if any.
  - c. Improve the skill set from past experience of reporting senior.
  - d. Aware of latest technology from reporting senior.
  - e. Support from and mutual understanding with reporting senior.
  - f. Helps to get rewards and salary hike.
3. What are the benefits of communicating work techniques and methods with colleagues? 1 Mark
- Possible answers**
- a. Clarity on schedule and outcome.
  - b. Clarity on the method used.
  - c. Clarity on individual and team responsibility
  - d. Save time and avoid material wastage.
  - e. Optimum usage of resources.
  - f. Improve skills by knowledge sharing.
  - g. Help and support within the team.
  - h. Improve the team bonding.



4. What are the advantages of getting clarification and advice?

1 Mark

**Possible answers**

- a. Clarity on task to be executed.
- b. Improve knowledge and skill.
- c. Avoid material wastage.
- d. Effective usage of resources.
- e. Timely completion of task.
- f. Better bond between the team.

5. How can one team co-operate with interfacing teams?

3 Marks

**Possible answers**

- a. Timely handing over the tools and equipment to the interfacing teams.
- b. Timely handing over the work fronts to the interfacing teams.
- c. Share useful information's with interfacing team.
- d. Receive and share feedback with interfacing teams.
- e. Strictly follow the schedule, which is planned mutually with the interfacing teams.

6. What should be done when team has heavy work load but you were able to finish your part of work early?

3 Marks

**Possible answers**

- a. Extend help to team mates to complete their work.
- b. Ask for any required help to finish the work.
- c. Motivate the team to complete their task
- d. Try to accelerate the speed by providing required resources in time.



## 7.6 CON/N8002: Plan and organize work to meet expected outcomes

### A. Practical questions

70 Marks

Assessor is required to assess this NOS bases on his/her observation skill and knowledge to observe, ask questions and assess trainee while performing all core NOS's during the practical task for following points:

1. How a person understand the targets and time line set by supervisor. 15 Marks
  - Is candidate able understand the target clearly? (**compulsory**) (Ex. Understanding electrical diagram, Type of electrical fixtures and fittings, duration for each task etc.)
2. How a person plan activities as per schedule and sequence. 10 Marks
  - Is candidate able to explain the plan and sequence before performing any core task?  
(**Compulsory:** assessor to ask candidate to explain the sequence of task (for any core task)
3. How a person provide guidance to the subordinates to obtain desired outcome. 10 Marks
  - Is candidate able to guide other candidate while working together? (Ex. While marking groove cutting layout in wall, transferring level using tube level etc.)
4. How a person arrange required resources prior to commencement of work. 15 Marks
  - Is candidate able to arrange right quantity of material? (Ex. Right length of conduits and wire, number of fixtures, fittings, number of helpers, tools etc.)
5. How a person utilize resources effectively during performing the task. 10 Marks
  - Is candidate able to use the correct length of conduit pipes, cables, number of fixtures, fittings properly as per the instruction/drawing?
  - Is able to engage helpers properly?
6. How a person adhere to the standard instructions while performing the task. 10 Marks
  - Is candidate able to follow standard instructions? (Ex. Class room discipline, using proper PPE's, care on surrounding environments etc.)

### B. Theory questions (Written)

Total Marks: 20

1. What is the purpose of work schedule? 1 Mark
  - a. **To track the work progress**
  - b. To track the quality of work
  - c. To track the welfare of workers
  - d. To track the attendance of workers
2. What best can be done if a colleague is found to be in a problem while executing a task? 3 Marks
  - a. Force him to do it himself
  - b. Inform about it to the customer
  - c. Complain to the reporting senior and continue with the job
  - d. **Provide guidance and help him with known skills**
3. When should waste materials be cleared from the workplace? 2 Marks
  - a. After completion of entire project
  - b. **Every day before leaving site**
  - c. Once in three days
  - d. Once in ten days
4. Which among these is the most essential tool to carry out termination? 3 Marks
  - a. **Splicer**
  - b. Scissor
  - c. Hacksaw
  - d. Knife



5. Which of the following is **not** considered as a resource to execute the task? 6 Marks
- Manufacturer**
  - Material
  - Manpower
  - Machineries
6. Which of the following is the best method to reduce material wastage? 1 Mark
- Use damaged materials
  - Do not use defective tool**
  - Mix waste materials with new materials
  - Take rough measurements while cutting a conduit
7. Whose instructions should be followed while using an equipment? 4 Marks
- General instructions
  - Manufacturer instructions**
  - Dealer instructions
  - Colleagues instructions

### **C. Viva questions**

**Total Marks: 10**

1. What are the advantages of work schedule? 3 Marks
- Possible answers**
- To understand the work to be done.
  - To know the time line to complete the work.
  - To understand and organise the resources to execute the task.
  - To know the sequence of work to be executed.
  - To track the status and work progress.
  - To utilise time and resources most effectively.
2. What are the benefits of providing guidance to the subordinates? 3 Marks
- Possible answers**
- Improve skill sets of subordinates.
  - Update on latest technologies.
  - Proper control on anticipated hurdles.
  - Avoid mistakes and save time.
  - Help to improve the quality of output.
  - Help to utilize resources most effectively.
  - Helps to improve team bonding.
3. How can one reduce material wastages while executing the task? 4 Marks
- Possible answers**
- Clarity on the task to be done.
  - Select proper method to execute task.
  - Select right material and tool for right job.
  - Ensure exact measurements while cutting the materials.
  - Optimum utilization of materials.
  - Follow proper handling techniques for tools and material
  - Avoid mixing of usable materials with waste.
  - Return excess materials and tools to the store



## 7.7 CON/N9001: Work according to personal health, safety and environment protocol at construction site

### A. Practical questions

**70 Marks**  
**30 Minutes**

Assessor is required to assess this NOS bases on his/her observation skill and knowledge to observe, ask questions and assess trainee while performing all core NOS's during the practical task for following points (If particular outcome is not covered in any of the core NOS's, assessor need to insist candidate to perform the activities):

1. How person identify hazards, risks in site and report to seniors 6 Marks
    - Is candidate able to escalate hazards, risks to the senior? (Ex. Damaged tools, unguarded machineries, inadequate illumination, co-worker working at height without using safety harness, damaged electrical cables etc.)
  2. How a person respond to emergency and evacuation procedures in case of accidents, fires. 6 Marks
    - Is candidate able to explain the emergency evacuation procedure in case of different emergencies? (Ex. Fire, building collapse, flood etc.)
  3. Use of personal protective equipment listed below (**Compulsory**). 30 Marks

(Use of PPEs specified at NOS is mandatory for all the assessee and candidate should score 100% mark in this particular outcome.)

    - Is candidate able to demonstrate the use of all personal protective equipment's? (Ex. Helmet, **harness**, safety goggles, safety shoes, hand gloves, gum boot, **earplug**, dust mask, **reflective jacket**, **shoulder pack**, etc.)
    - Is the candidate able to list PPE's as per the particular task? (Ex. While plastering, while water proofing, while IPS flooring etc.)
  4. Identification and operation procedure for fire extinguishers. 8 Marks
    - Is candidate able to identify different types of fire extinguishers? (Ex. DCP, CO2, Foam etc.).
    - Is candidate able to demonstrate the operating procedure for different types of fire extinguishers? (Assessor to insist candidate to perform this task)
  5. Handling technique of tools, materials and equipment. 8 Marks
    - Is candidate able to explain the handling techniques of tools, materials and equipment? (Ex. Cement bags, bricks, spirit level, drilling machine, vibrators etc.)
  6. Adhere to safe working practices while working at height, using tools and equipment, material shifting, working with hazardous materials etc. 6 Marks
    - Is candidate able to place ladder safely?
    - Is candidate able to follow precautionary measures in disposal of harmful chemicals?
  7. Ensure cleaning, housekeeping and waste disposal. 6 Marks
    - Is candidate able to plan housekeeping while performing the task?
- Is candidate able explain the method to shift waste to designated yard? (Ex. Through wheel barrow, through chute, through open dump etc.)

### B. Theory questions (Written)

**Total Marks: 20**

1. Which of the following is an unsafe working condition? 2 Marks
  - a. **Working on electrical equipment connected with damaged wire**
  - b. Working at a height with safety belt
  - c. Working on electrical equipment connected with insulated cable
  - d. Working with a chasing machine connected with industrial socket





2. Which of the following safety trainings is mandatory for workers before entering a new site? 2 Marks
- a. **Induction training**
  - b. First aid training
  - c. Refresher training
  - d. Specific training
3. Which of the following should be referred before handling chemicals? 3 Marks
- a. **Material safety data sheet**
  - b. Material test certificate
  - c. Material delivery sheet
  - d. Material invoice letter
4. Which of the following is the minimum height at which a safety belt must be worn? 3 Marks
- a. 3 meters
  - b. **2 meters**
  - c. 4 meters
  - d. 1 meter
5. Which of the following is **not** the method for waste disposal? 2 Marks
- a. Incineration
  - b. Recycling
  - c. **River dump**
  - d. Landfills
6. Which one of the following is **not** a safety requirement for a power tool? 4 Marks
- a. Make sure that the machine is in good working condition
  - b. Make sure that the machine has safety guards
  - c. Make sure that the operator is trained properly
  - d. **Make sure that the machine is brand new**
7. What is firefighting? 4 Marks
- a. Working with fire
  - b. **Process of extinguishing fire**
  - c. Study about fire
  - d. Working in hot areas

### C. Viva questions

**Total Marks: 10**

1. What are the possible hazards and accidents while working near the electrical equipment? 1 Mark
- Possible answers**
- a. Shock.
  - b. Burns.
  - c. Radiation.
  - d. Loss of consciousness.
  - e. Loss of limb or life
  - f. Permanent disability.
  - g. Injuries.



2. What are the possible unsafe behaviour and attitude of workers? 1 Mark  
**Possible answers**  
a. Not following safety rules, warning signs and danger notices.  
b. Not wearing protective clothing.  
c. Performing job without authorization.  
d. Using defective tools and equipment.  
e. Operating machines without safety guards.  
f. Bulling co-workers.  
g. Consuming alcohol, drugs and tobacco.  
h. Poor housekeeping.
3. What are the information's available in an emergency preparedness plan? 1 Mark  
**Possible answers**  
a. Emergency coordinators name and contact number.  
b. Details of emergency response team with contact number.  
c. Functions of emergency response team.  
d. The means of escape.  
e. Contact numbers of emergency services like, police, fire, ambulance etc.  
f. Site plan with the location of emergency equipment.  
g. List of suppliers of emergency equipment
4. What are the possible hazards involved while working with toxic substances? 1 Mark  
**Possible answers**  
a. Burns.  
b. Scalds.  
c. Skin irritations  
d. Respiratory problems.  
e. Nausea.  
f. Dizziness.  
g. Loss of consciousness.
5. What are the benefits of attending health and safety campaigns? 1 Mark  
**Possible answers**  
a. Understand the requirement of health and safety.  
b. Know about common types of hazards.  
c. Risk assessment and risk control.  
d. Know how to use PPE.  
e. Know about the common terms and signage used in safety.  
f. Know about the company standards on safety.  
g. Know about safe working practices.  
h. Know emergency response procedure and first aid.
6. What are the precautionary steps to be taken to avoid accidents while using equipment? 1 Mark  
**Possible answers**  
a. Use required PPE while using equipment.  
b. Use the right type of equipment for the job.  
c. Do not use damaged and unconditioned equipment.  
d. Ensure safety guard for the tool.  
e. Ensure electrical safety if the equipment is power driven.  
f. Do not wear loose cloth and jewellery while using equipment



- g. Do not work with oily/greasy hands.
- h. Keep people away from the equipment while using.

7. State the purpose of waste disposal

2 Marks

**Possible answers**

- a. To maintain cleanliness
- b. To avoid accidents
- c. To avoid mixing of useful materials with waste
- d. To avoid fire hazards
- e. To utilise the area effectively

8. Explain what has to be done when a worker is injured at the work place. Assume the person is bleeding.

2 Marks

**Possible answers**

- a. Try to stop the bleeding first.
- b. Shift the injured person to the first aid room with the support of other workers.
- c. Explain the incident to the doctor and safety team to enable them to start treatment.
- d. Report the incident to the management.
- e. Prepare and share the action plan to avoid such incidents in future.



## 8. Assessment summary

### Assessor's comments

.....

.....

.....

This is to confirm that the trainee has undertaken the assessment for the job role of Assistant Electrician.

Trainee's signature: \_\_\_\_\_

Trainee's name (please print): \_\_\_\_\_

Assessor's signature: \_\_\_\_\_

Assessor's name (please print): \_\_\_\_\_

Centre Head's seal and signature: \_\_\_\_\_

Trainee's photo ID (other than the Institute ID): \_\_\_\_\_

Assessment completion date: \_\_\_\_\_



## 9. Assessment Evidence Form

**Trainee name:**

**Trainee roll number:**

**Centre name/ Code Date:**

This is to confirm that the trainee has handed over the final job to the assessor.  
(For each task separate sheet can be used)

Assessor to affix photographs of the practical output (end product)

Trainee's signature:

---

Trainee's name (please print):

---

Assessor's signature:

---

Assessor's name (please print):

---

Centre Head's seal and signature:



---





## 10. Annexure : Assessment sheet

ASSESSMENT SUMMARY		Assessment / Tested For : Assistant Electrician level-3		 <small>N.S.D.C. National Skill Development Corporation</small>								
Training Provider :				Testing Centre:								
Affiliation No.:				Accreditation No.:								
		Roll No. :	Roll No. :	Roll No. :	Roll No. :							
		Batch:	Batch:	Batch:	Batch:							
		Name:	Name:	Name:	Name:							
<b>Assessment Summary :</b>												
NOS No.	Allotted (Marks)		Obtained		Obtained		Obtained		Obtained		Obtained	
	Skill	Knowledge	Skill	Knowledge	Skill	Knowledge	Skill	Knowledge	Skill	Knowledge	Skill	Knowledge
CON/N0602 (70%)	70	30										
CON/N0603 (70%)	70	30										
CON/N0604 (70%)	70	30										
CON/N0605 (70%)	70	30										
CON/N8001(70%)	70	30										
CON/N8002 (70%)	70	30										
CON/N9001 (100%)	70	30										
<b>Total = 700</b>	<b>490</b>	<b>210</b>										
<b>Percentage weightage</b>	70	30										
<b>Minimum Marks required to qualify obtained (%)</b>	70%	50%										
			Result : Passed/Failed		Result : Passed/Failed		Result : Passed/Failed		Result : Passed/Failed		Result : Passed/Failed	
Assessors Name:						Signature						
Assessing Body Representative Name:						Signature						
Assessment Agency :						Date:						



	Sr. NO.1. Roll No. & Name:	Sr. NO.4. Roll No. & Name:							
	Sr. NO.2. Roll No. & Name:	Sr. NO.5. Roll No. & Name:							
	Sr. NO.3. Roll No. & Name:	Sr. NO.6. Roll No. & Name:							
		Obtained Marks							
Element	Skills (Total Marks = 70)	Allocated Marks	Sr.NO.1	Sr.NO.2	Sr.NO.3	Sr.NO.4	Sr.NO.5	Sr.NO.6	
QP : QP : Assistant electrician QP : CON/Q0602	1. Identify and demonstrate use of hand/ measuring tools (any 5 tools)	5							
	2. Identify and demonstrate use of power tools while using appropriate PPEs	10							
CON/N0602: Select and use hand, power tools and electrical devices relevant to construction electrical works.	3. Identify and demonstrate use of common electrical measuring devices as per standard procedure of power tools (any two)	10							
	4. Describe the use of commonly used electrical fixtures, and electrical materials (any two)	10							
	5. Measure the size of given wire using a Standard Wire Gauge (SWG)	5							
	6. Measure the diameter using a Vernier calliper.	5							
	7. Measure the resistance of wires using a multi meter	5							
	8. Measure and note load current in a cable by using clamp-on ammeter	5							
	9. Demonstrate use of PPEs used for electrical works (any five)	15							
	<b>Total Marks</b>	<b>70</b>							
	Knowledge (Total Marks =30)								
		1. Knowledge of measuring devices	4						
	2. Knowledge of tools	4							
	3. Knowledge of power tools	4							
	4. Knowledge of electrical fittings and fixtures	4							
	4. Knowledge of tools maintenance practices	3							
	5. Knowledge of electrical symbols	3							
	7. Knowledge of SLD & wiring diagram	4							
	8. Knowledge of safe working practices	4							
	<b>Total Marks</b>	<b>30</b>							
<b>Batch No. &amp; TP:</b>									
Assessors Reg. No. :	Assessors Name:				Assessors Signature :				
	Assessors Body(AB) Representative Name:				AB Representative Signature :				
Assessment Agency :					Date :				





	Sr. NO.1. Roll No. & Name:	Sr. NO.4. Roll No. & Name:							
	Sr. NO.2. Roll No. & Name:	Sr. NO.5. Roll No. & Name:							
	Sr. NO.3. Roll No. & Name:	Sr. NO.6. Roll No. & Name:							
<b>Element</b>	<b>Skills (Total Marks = 70)</b>	<b>Obtained Marks</b>							
		Allotted Marks	Sr.NO.1	Sr.NO.2	Sr.NO.3	Sr.NO.4	Sr.NO.5	Sr.NO.6	
QP : QP : Assistant electrician QP : CON/Q0602	Check and select cable, conduits, lights, sockets and related fittings	10							
	2. Carryout laying of cables through underground by suitable trenches	10							
CON/N0603 : Install temporary lighting arrangement at construction sites	3. Extend LV electrical cable using proper joints.	10							
	4. Terminate LV cables using right method.	10							
	5. Carryout earthing as per standard method.	10							
	6. Fix light and accessories as per the requirement and electrical safety guidelines.	10							
	7. Carry out relevant tests to trace out power interruptions/ continuity at lighting arrangements	10							
	<b>Total Marks</b>	<b>70</b>							
	<b>Knowledge (Total Marks =30)</b>								
		1. Knowledge of electrical wires	3						
	2. Knowledge of electrical socket	4							
	3. Knowledge of cable joint	4							
	4. Knowledge of terminating wires	4							
	4. Knowledge of lighting fixture	4							
	5. Knowledge of measuring devices	3							
	6. Knowledge of electrical symbols	4							
	7. Knowledge of circuit breakers	4							
	<b>Total Marks</b>	<b>30</b>							
<b>Batch No. &amp; TP:</b>									
Assessors Reg. No. :	Assessors Name:		Assessors Signature :						
	Assessors Body(AB) Representative Name:		AB Representaive Signature :						
Assessment Agency :			Date :						







	Sr. NO.1. Roll No. & Name:	Sr. NO.4. Roll No. & Name:						
	Sr. NO.2. Roll No. & Name:	Sr. NO.5. Roll No. & Name:						
	Sr. NO.3. Roll No. & Name:	Sr. NO.6. Roll No. & Name:						
<b>Element</b>	<b>Skills (Total Marks = 70)</b>	<b>Allo- t- ted Marks</b>	<b>Obtained Marks</b>					
			Sr.NO.1	Sr.NO.2	Sr.NO.3	Sr.NO.4	Sr.NO.5	Sr.NO.6
QP : Assistant electrician QP : CON/Q0602	1. Read and interpret Single Line Diagrams (SLDs) for below shown	7						
	2. Check and select cable, conduits, lights, sockets and related fittings	7						
	3. Measure length of conduits and cables	10						
CON/N0604: Install LV electrical wiring at permanent structure	4. Tag conduits through RCC structure and wall	8						
	5. Lock conduit pipes in its location	8						
	6. Push & pull wires through conduits	8						
	7. Perform drilling and cutting work	10						
	8. Extend LV electrical cable using proper joints	6						
	9. Terminate LV cables using right method.	6						
	<b>Total Marks</b>	<b>70</b>						
	<b>Knowledge (Total Marks =30)</b>							
	1. Knowledge of 1 phase/ 3 phase wiring system	4						
	2. Knowledge of reading and interpreting SLD & wiring diagram	6						
3. Knowledge of using hand and power tools.	4							
4. Knowledge of measuring / diagnosis electrical wiring	4							
5. Knowledge of conduit laying systems,	4							
6. Knowledge of wiring specification	4							
7. Understands basic electrical principals and measuring equipments	4							
<b>Total Marks</b>	<b>30</b>							
<b>Batch No. &amp; TP:</b>								
Assessors Reg. No. :	Assessors Name:	Assessors Signature :						
	Assessors Body(AB) Representative Name:	AB Representative Signature :						
Assessment Agency :	Date :							





	Sr. NO.1. Roll No. & Name:	Sr. NO.4. Roll No. & Name:							
	Sr. NO.2. Roll No. & Name:	Sr. NO.5. Roll No. & Name:							
	Sr. NO.3. Roll No. & Name:	Sr. NO.6. Roll No. & Name:							
		<b>Obtained Marks</b>							
<b>Element</b>	<b>Skills (Total Marks = 70)</b>	<b>Allo tted Marks</b>	<b>Sr.NO.1</b>	<b>Sr.NO.2</b>	<b>Sr.NO.3</b>	<b>Sr.NO.4</b>	<b>Sr.NO.5</b>	<b>Sr.NO.6</b>	
QP : Assistant electrician QP : CON/Q0602	1. Check and select required materials and fittings as per the below drawing	8							
	2. Measure and mark all fittings, fixtures and components in distribution board as per the drawing	8							
	3. Carryout required opening (Cut/hole) in distribution board using appropriate tools.	10							
CON/N0605 : Assemble, install and maintain LV electrical panels ( distributes boards)	4. Carryout wiring using required tools and materials as per the drawing	15							
	5. Terminate LV cables using right method.	10							
	6. Carryout earthing as per standard method.	8							
	7. Carry out relevant tests to trace out power interruptions/ continuity at lighting arrangements	6							
	8. Place and safe guard distribution board as per the guidelines	5							
	<b>Total Marks</b>	<b>70</b>							
	<b>Knowledge (Total Marks =30)</b>								
		1. Knowledge of 1 phase/ 3 phase wiring system	6						
	6. Knowledge of wiring specification	6							
	4. Knowledge of measuring / diagnosis electrical wiring	6							
	5. Knowledge of conduit laying systems,	6							
	3. Personal protection equipments	6							
	<b>Total Marks</b>	<b>30</b>							
<b>Batch No. &amp; TP:</b>									
Assessors Reg. No. :	Assessors Name:			Assessors Signature :					
	Assessors Body(AB) Representative Name:			AB Representaive Signature :					
Assessment Agency :			Date :						





	1. Roll No. & Name:	4. Roll No. & Name:						
	2. Roll No. & Name:	5. Roll No. & Name:						
	3. Roll No. & Name:	6. Roll No. & Name:						
		<b>Marks Obtained by candidates</b>						
<b>QP &amp; NOS Detail</b>	<b>Skills (Total Marks = 70)</b>	<b>Allotted Marks</b>	<b>1</b>	<b>2</b>	<b>3</b>	<b>4</b>	<b>5</b>	<b>6</b>
QP : Assistant electrician QP : CON/Q0602	1. How the candidate communicate work related information to team member or to assessor	10						
	2. How the candidate escalate deviations to the seniors/assessor	15						
CON/N8001: Work effectively in a team to deliver desired results at the workplace	3. How the candidate address and report problems	15						
	4. How a person receive and follow the instructions given by seniors/assessor	10						
	5. How a person seek clarifications and resolve the issues raised during performing the task	10						
	6. How a person work as team like, proper cooperation, timely handing over tools and materials, helping and advising team members	10						
	<b>Total Marks</b>	<b>70</b>						
	<b>Knowledge -(Total Marks =30)</b>							
	1. Knowledge about the advantage of working in a team	6						
	2. Knowledge about the work schedule	6						
	3. Knowledge about the importance of communication with team	6						
	4. Knowledge about the escalation and reporting problems	6						
	5. Knowledge about the importance of inter team discussion	6						
	<b>Total Marks</b>	<b>30</b>						
<b>Batch No. &amp; TP:</b>								
Assessors Reg. No. :	Assessors Name:		Assessors Signature :					
	Assessors Body(AB) Representative Name:		AB Representative Signature :					
Assessment Agency :			Date :					



	1. Roll No. & Name:	4. Roll No. & Name:							
	2. Roll No. & Name:	5. Roll No. & Name:							
	3. Roll No. & Name:	6. Roll No. & Name:							
		<b>Marks Obtained by candidates</b>							
<b>QP &amp; NOS Detail</b>	<b>Skills (Total Marks = 70)</b>	<b>Allotted Marks</b>	<b>1</b>	<b>2</b>	<b>3</b>	<b>4</b>	<b>5</b>	<b>6</b>	
<b>QP : Assistant electrician</b> <b>QP : CON/Q0602</b>  <b>CON/N8002: Plan and organize work to meet expected outcomes</b>	1. How a person understand the targets and time line set by supervisor	15							
	2. How a person plan activities as per schedule and sequence.	10							
	3. How a person provide guidance to the subordinates to obtain desired outcome	10							
	4. How a person arrange required resources prior to commencement of work.	15							
	5. How a person utilize resources effectively during performing the task.	10							
	6. How a person adhere to the standard instructions while performing the task	10							
	<b>Total Marks</b>	<b>70</b>							
	<b>Knowledge -(Total Marks =30)</b>								
	1. Knowledge about the targets and time line to complete the task	4							
	2. Knowledge about the work schedule	5							
	3. Knowledge about benefits of providing guidance to the subordinates	5							
	3. Knowledge about the importance of team	5							
	3. Knowledge about the waste disposal	5							
4. Knowledge about the utilization of resources	6								
<b>Total Marks</b>	<b>30</b>								
<b>Batch No. &amp; TP:</b>									
<b>Assessors</b> Reg. No. :	Assessors Name:	Assessors Signature :							
	Assessors Body(AB) Representative Name:	AB Representative Signature :							
<b>Assessment Agency :</b>		<b>Date :</b>							



	1. Roll No. & Name:	4. Roll No. & Name:						
	2. Roll No. & Name:	5. Roll No. & Name:						
	3. Roll No. & Name:	6. Roll No. & Name:						
		<b>Marks Obtained by candidates</b>						
<b>QP &amp; NOS Detail</b>	<b>Skills (Total Marks = 70)</b>	<b>Allotted Marks</b>	<b>1</b>	<b>2</b>	<b>3</b>	<b>4</b>	<b>5</b>	<b>6</b>
QP : Assistant electrician QP : CON/Q0602	1. How person identify hazards, risks in site and report to seniors	6						
	2. How a person respond to emergency and evacuation procedures in case of accidents, fires	6						
CON/N9001: Work according to personal health, safety and environment protocol at construction site	3. Use of personal protective equipment listed below (Compulsory).	30						
	4. Identification and operation procedure for fire extinguishers	8						
	5. Handling technique of tools, materials and equipment	8						
	6. Adhere to safe working practices while working at height, using tools and equipment, material shifting, working with hazardous materials etc.	6						
	7. Ensure cleaning, housekeeping and waste disposal	6						
	<b>Total Marks</b>	<b>70</b>						
	<b>Knowledge -(Total Marks =30)</b>							
	1. Knowledge about unsafe working practices	3						
	2. Knowledge about how to handle chemicals	3						
	3. Knowledge about safety belt	3						
	4. Knowledge about the basic needs to operate a power tool	6						
	5. Knowledge about emergency preparedness plan	3						
	6. Knowledge of working with toxic substances	3						
	7. Knowledge about the benefits of attending health and safety campaigns	3						
	8. Knowledge about the waste disposal	3						
	9. Knowledge about first aid	3						
	<b>Total Marks</b>	<b>30</b>						
<b>Batch No. &amp; TP:</b>								
Assessors Reg. No. :	Assessors Name:	Assessors Signature :						
	Assessors Body(AB) Representative Name:	AB Representative Signature :						
Assessment Agency :		Date :						